

## GROUP 52B

# SUPPLEMENTAL RESTRAINT SYSTEM (SRS)

## CONTENTS

<b>GENERAL DESCRIPTION</b> .....	<b>52B-2</b>	CLOCK SPRING .....	52B-14
<b>SYSTEM OPERATION</b> .....	<b>52B-9</b>	FRONT IMPACT SENSOR .....	52B-15
FRONT AIR BAG AND SEAT BELT WITH PRE-TENSIONER .....	52B-9	SIDE IMPACT SENSOR .....	52B-15
SIDE AND CURTAIN AIR BAGS .....	52B-10	SEAT SLIDE SENSOR .....	52B-16
<b>SYSTEM CONSTRUCTION</b> .....	<b>52B-11</b>	OCCUPANT CLASSIFICATION SENSOR .	52B-17
DRIVER'S AIR BAG MODULE .....	52B-11	SEAT BELT WITH PRE-TENSIONER. ....	52B-18
FRONT PASSENGER'S AIR BAG MODULE	52B-12	PASSENGER SEAT BELT WARNING LIGHT .....	52B-18
SIDE AIR BAG MODULE .....	52B-13	PASSENGER AIR BAG OFF INDICATOR LIGHT .....	52B-19
CURTAIN AIR BAG MODULE .....	52B-14	SRS-ECU .....	52B-19
		SRS AIR BAG SPECIAL CONNECTOR ...	52B-25

## GENERAL DESCRIPTION

M2521000100455

*NOTE: In this manual, the part names are changed from the names in owner's manual into the following names.*

- *Driver's seat position sensor* → *Seat slide sensor*
- *Passenger's seat weight sensor* → *Occupant classification sensor*
- *Seat belt buckle switch* → *Seat belt switch*
- *Passenger air bag off indicator* → *Passenger air bag OFF indicator light*
- *Front passenger seat belt warning light* → *Passenger seat belt warning light*

Driver's and front passenger's air bags and seat belt pre-tensioners deploy and operate in head-on collisions that exceed the criteria to activate the SRS system.

The front air bag deploys when a vehicle collides head-on with a concrete (fixed) wall at approximately 25 km/h (15 mph) or more, or when a vehicle suffers a severe impact from the front side.

The side air bag deploys when a center of side body suffers a severe impact.

The front air bags and pre-tensioners may not work under the following conditions:

- A head-on collision is less than the criteria.
- The collision is from the rear
- The collision is from the side
- The vehicle rolls over or is in a similar position.

The side-airbags and curtain air bag may not work under the following conditions:

- A side-collision is less than the criteria.
- The collision is from the front
- The collision is from the rear
- The vehicle rolls over or is in a similar position.

Driver's and front passenger's and side and curtain air bags and seat belts with pre-tensioner are standard equipment.

### SUPPLEMENTAL RESTRAINT SYSTEM (SRS)

The SRS is designed to supplement the front seat belts. It reduces injury to the driver(s) and the front passenger(s) by deploying air bag(s) in case of a head-on collision.

The SRS front air bags from an advanced air bag system together with sensors at the vehicle and sensors attached to front seats.

### SRS SIDE-AIRBAG

Side-airbag systems in the front seats are activated when side impacts exceed criteria to protect the occupants' upper bodies.

### SRS CURTAIN AIR BAG

The curtain air bag systems are activated when sideward impacts applied to the vehicle exceed criteria, to protect the heads of the occupants in the front seats.

### SEAT BELT WITH PRE-TENSIONER

The seat belts with pre-tensioner work simultaneously with the SRS. The seat belt incorporating the pre-tensioner automatically winds the seat belt upon front impact to reduce forward shifting of the driver's and passenger's. The seat belt use status is used to control the activation and deactivation of the pre-tensioner.

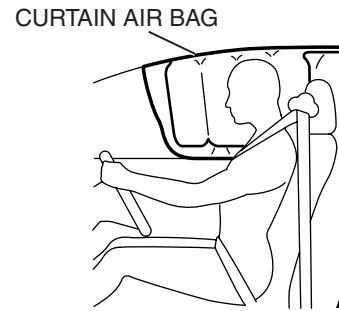
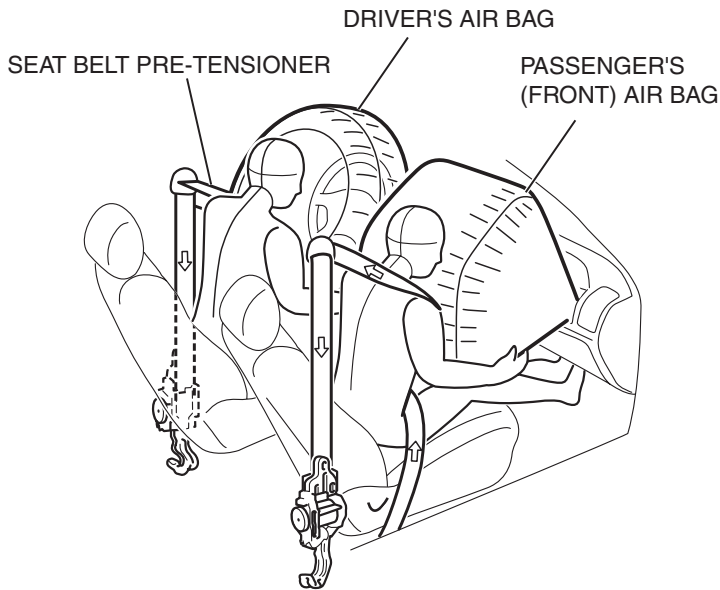

AC406296

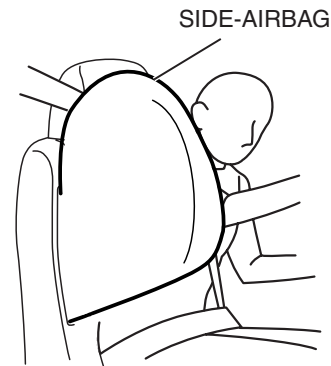

AC406708 AB

**SYSTEM COMPONENT PARTS**

The SRS and seat belt pre-tensioner systems consist of air bag modules, SRS-ECU, two front impact sensors, two side impact sensors, SRS warning light, clock spring, driver's seat slide position sensor, passenger's occupant classification sensor, passenger air bag OFF indicator light, passenger seat belt warning light and seat belt pre-tensioner. Air bags are located in the center of the steering wheel, above the glove box, the right and left side of the headlining, and in the front seatback assemblies. Each air bag has a safing folded air bag and an inflator. The SRS-ECU under the front floor console monitors the system. The front impact sensor is assembled in the radiator support panel to monitor collision upon frontal impact. The side impact sensor is assembled in the center pillar to monitor collision upon side impact. The warning light on the instrument panel indicates the operational status of the SRS. The clock spring is installed in the steering column. The seat slide sensor is attached to the seat rail and provides the air bag control unit with information on the seat position. The occupant classification sensors are attached to the seat rails and provide the air bag control unit with information on the weight applied to the front passen-

ger seat. The passenger air bag OFF indicator light is located above the central vents in the instrument panel. The passenger seat belt warning light is located above the central vents in the instrument panel. The seat belt pre-tensioner is incorporated in the seat belt retractor. The seat belt switch detects whether the seat belt is used.

The SRS-ECU will start a squib ignition current to the driver's air bag module, front passenger's air bag module and seat belt pre-tensioner when simultaneously detecting frontal impact with the front impact sensor and the SRS-ECU. It will also supply a squib ignition current to the side-airbag module and curtain air bag module when simultaneously detecting side impact with the side impact sensor and the SRS-ECU.

The SRS-ECU has the following functions:  
This triggers the air bag modules.

- Power supply backup function that deploys or operates the air bag module and seat belt pre-tensioner within specific period, in case of power failure upon impact.
- Diagnostic test mode to improve safety and reliability.

CONSTRUCTION DIAGRAM

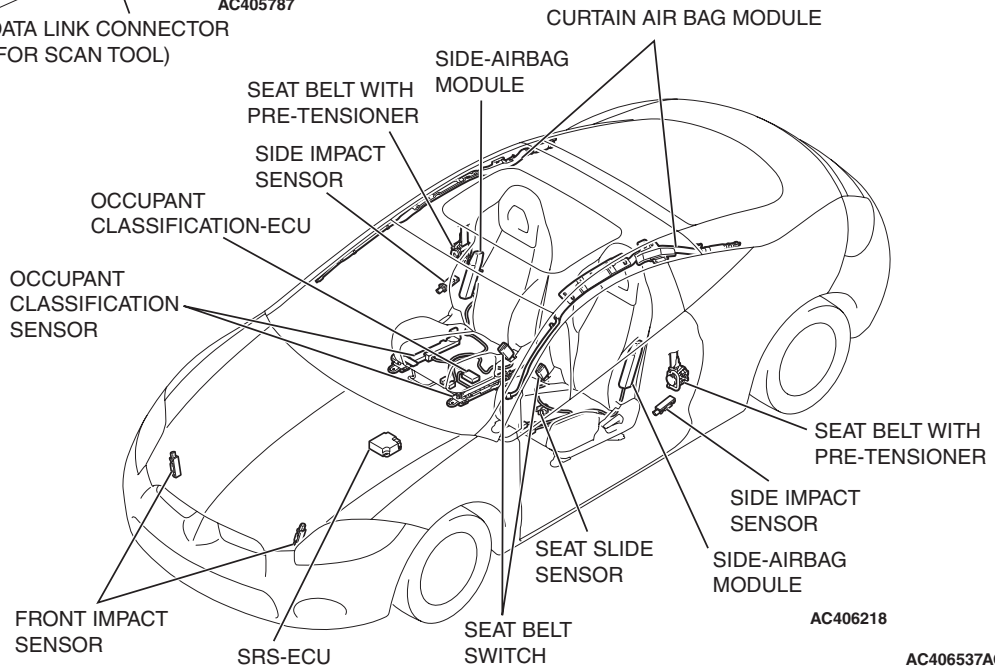
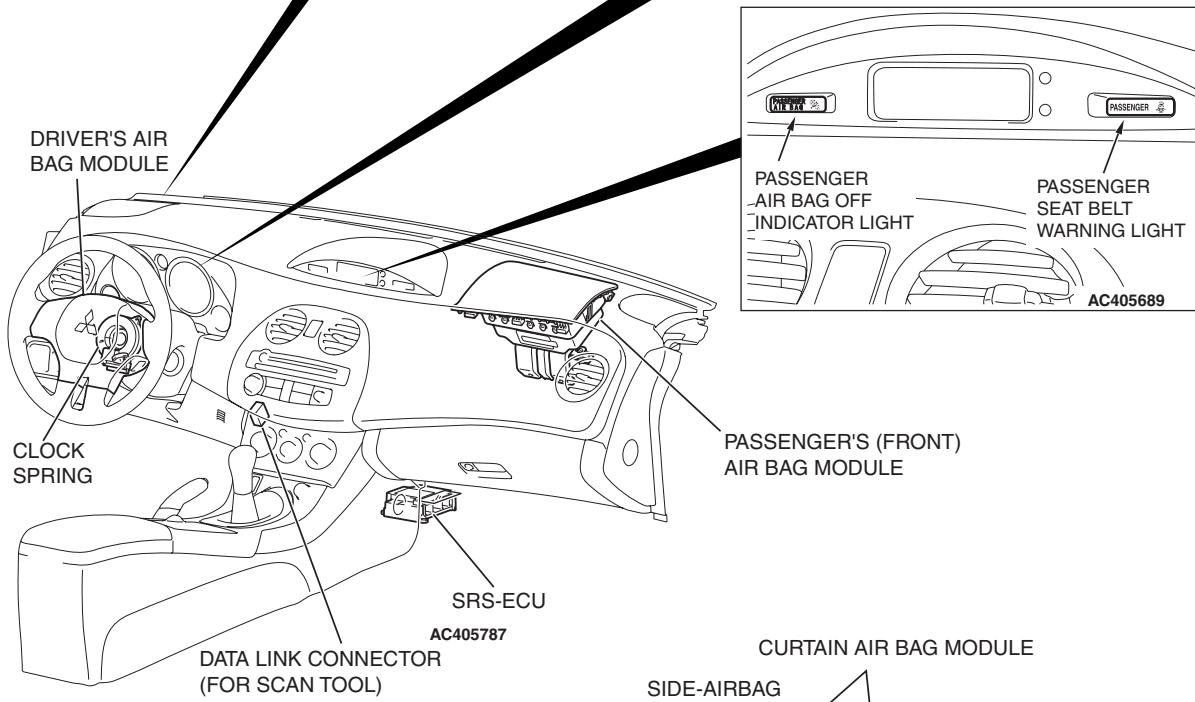
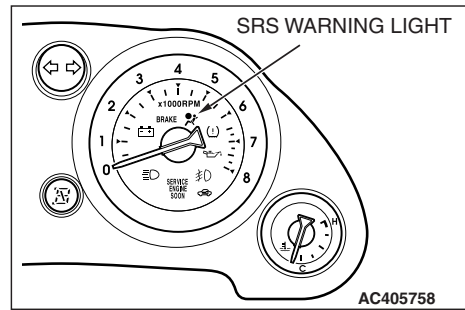
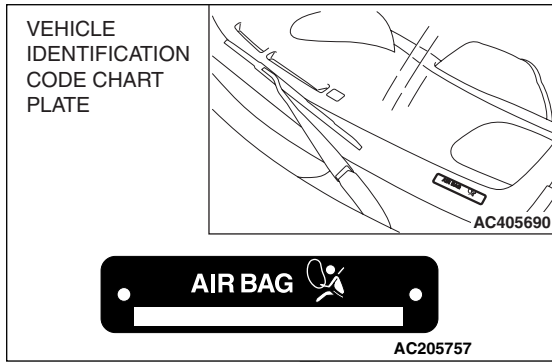

**SRS SYSTEM CIRCUIT DIAGRAM**

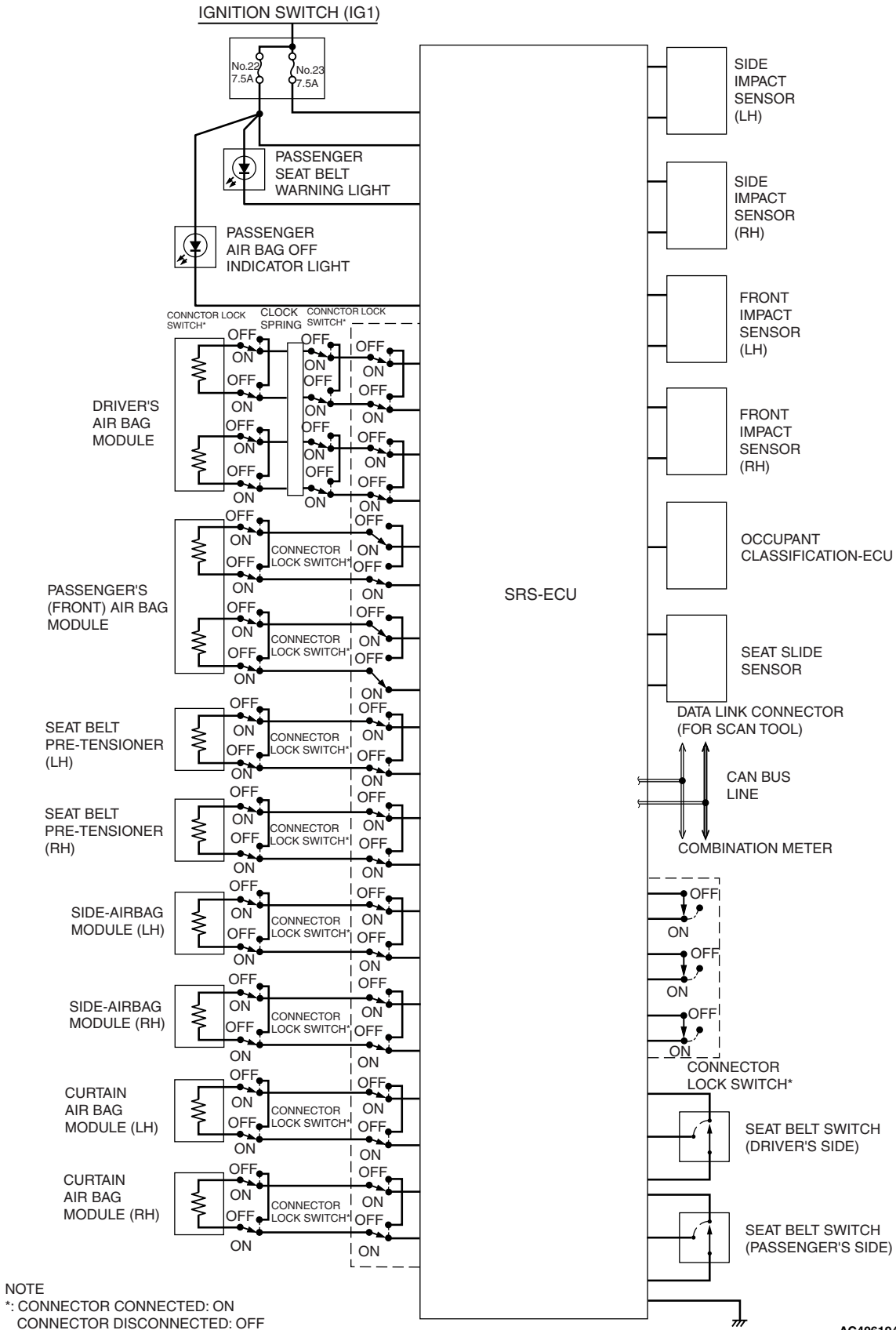

AC406194 AB

**CAUTION LABELS**

Labels to indicate cautions regarding the handling and the services of SRS air bag are attached in the positions shown in the following illustrations.

**DRIVER'S AIR BAG MODULE**

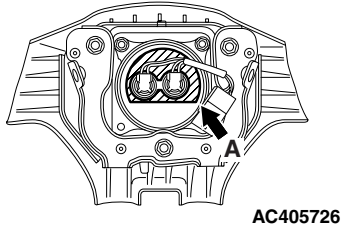

**CLOCK SPRING**

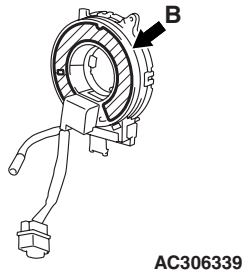

**PASSENGER'S AIR BAG MODULE**

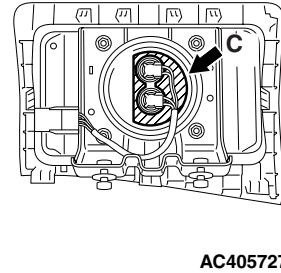

**SRS-ECU**

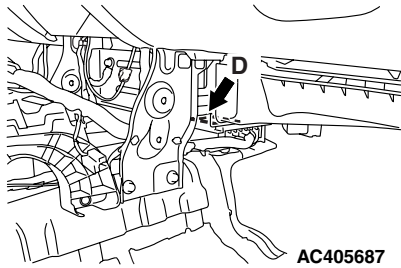

**SUN VISOR**

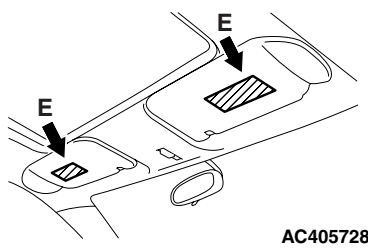

**GLOVE BOX**

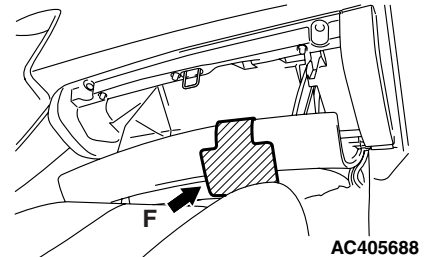

**SIDE-AIRBAG MODULE  
(DRIVER'S AND  
FRONT PASSENGER'S SEAT)**

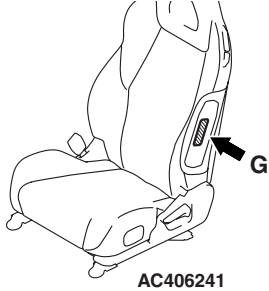

**SIDE IMPACT SENSORS  
(RH AND LH)**

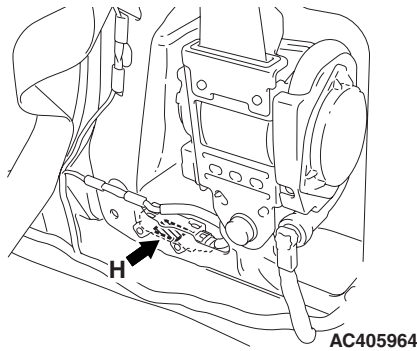

**SEAT BELT WITH PRE-TENSIONER  
(DRIVER'S AND FRONT  
PASSENGER'S SEAT BELT)**

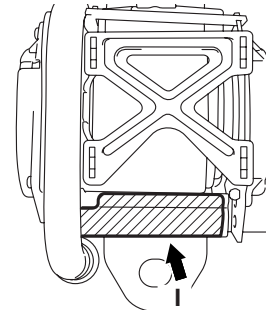

**FRONT IMPACT SENSORS  
(RH AND LH)**

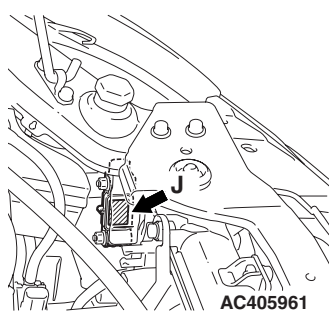

**CURTAIN AIR BAG**

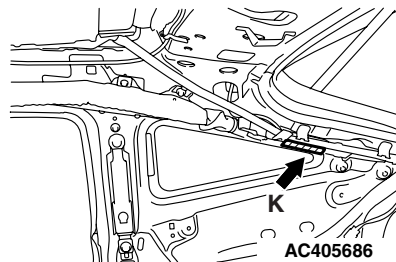

**HOOD**

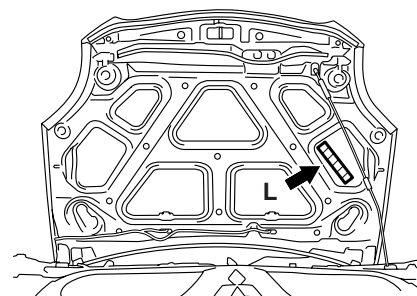

AC405685  
AC406531AB

<b>LABEL CONTENTS</b>	
A	<p><b>DANGER: FLAMMABLE MATERIAL</b> TO PREVENT PERSONAL INJURY, DO NOT DISMANTLE, INCINERATE, OR BRING INTO CONTACT WITH ELECTRICITY. STORE BELOW 200° F(93° C). READ SERVICE MANUAL FOR DETAIL.</p>
B	<p><b>CAUTION: SRS CLOCKSRING</b> THIS IS NOT A REPAIRABLE PART. IF DEFECTIVE REPLACE ENTIRE UNIT ACCORDING TO THE SERVICE MANUAL INSTRUCTIONS. TO RE-CENTER: ROTATE CLOCKWISE UNTIL TIGHT. THEN ROTATE IN OPPOSITE DIRECTION ROUGHLY 3 3/4 TURNS AND ALIGN ARROWS.</p>
C	<p><b>DANGER FLAMMABLE</b> <b>CAUTION THIS ASSEMBLY CONTAINS AN EXPLOSIVE INITIATOR.</b> <b>DANGER INFLAMMABLE</b> CONTENTS ARE EXTREMELY FLAMMABLE DO NOT PROBE WITH ELECTRICAL DEVICES OR OTHERWISE TAMPER WITH IN ANY WAY.</p>
D	<p><b>CAUTION:</b> DO NOT DISASSEMBLE OR DROP. IF DEFECT REFER TO SERVICE MANUAL.</p>
<p>E</p>  <p align="center">AC306673</p>	<p><b>WARNING</b> <b>EVEN WITH ADVANCED AIR BAGS</b></p> <ul style="list-style-type: none"> <li>• Children can be killed or seriously injured by the air bag</li> <li>• The back seat is the safest place for children</li> <li>• Never put a rear-facing child seat in the front</li> <li>• Always use seat belts and child restraints</li> <li>• See owner's manual for more information about air bags</li> </ul>

<b>LABEL CONTENTS</b>	
F	<p>This Vehicle is Equipped with Advanced Air Bags Even with Advanced Air Bags Children can be killed or seriously injured by the air bag. The back seat is the safest place for children. Never put a rear-facing child seat in the front. Always use seat belts and child restraints. See owner's manual for more information about air bags. Not to be removed except by owner.</p>
F <CANADA>	<p><b>WARNING</b> <b>MISE EN GARDE</b> Children Can Be <b>KILLED</b> or <b>INJURED</b> by Passenger Air Bag The back seat is the safest place for children 12 and under. Make sure all children use seat belts or child seats. Not to be removed except by owner.</p>
G	<p><b>DANGER FLAMMABLE MATERIAL</b> <b>SRS AIR BAG MODULE</b></p> <ul style="list-style-type: none"> <li>• Do not disassemble or impact.</li> <li>• Do not heat or incinerate.</li> <li>• Do not contact with electricity or tester probes.</li> <li>• Do not test or diagnose.</li> <li>• Do not store in more than 200° F (93° C).</li> <li>• Do not store the air bag with stud bolts pointing upwards.</li> <li>• For information on handing, replacement, and disposal methods, refer to the service manual.</li> </ul>
I	<p><b>DANGER: SEAT BELT PRE-TENSIONER</b> <b>CAUTION: THIS ASSEMBLY CONTAINS AN EXPLOSIVE INITIATOR</b> <b>FLAMMABLE MATERIAL</b> <b>TO PREVENT PERSONAL INJURY</b></p> <ul style="list-style-type: none"> <li>• <b>DO NOT IMPACT, DISMANTLE OR INSTALL IT INTO ANOTHER VEHICLE.</b></li> <li>• <b>SERVICE OR DISPOSE OF IT AS DIRECTED IN THE REPAIR MANUAL.</b></li> </ul>
H, J	<p><b>CAUTION:</b> <b>DO NOT DISASSEMBLE OR DROP.</b></p>
K	<p><b>DANGER</b> <b>SRS AIRBAG</b> CONTENTS ARE EXTREMELY FLAMMABLE. TO AVOID PERSONAL INJURY DUE TO ACCIDENTAL INFLATION, DO NOT PROBE WITH ELECTRICAL DEVICE OR OTHERWISE TAMPER WITH IN ANY WAY. FOLLOW SERVICE MANUAL INSTRUCTION CAREFULLY. "CAUTION-THIS ITEM CONTAINS AN EXPLOSIVE IGNITER."</p>
L	<p><b>WARNING</b> THIS VEHICLE HAS AN AIR BAG SYSTEM. REFER TO SERVICE MANUAL BEFORE SERVICING OR DISASSEMBLING UNDERHOOD COMPONENTS. READ THE "SRS" SECTION OF MANUAL FOR IMPORTANT INSTRUCTIONS. IMPROPER SERVICE PROCEDURES CAN RESULT IN THE AIR BAG FIRING OR BECOMING INOPERATIVE, POSSIBLY LEADING TO INJURY.</p>

# SYSTEM OPERATION

## FRONT AIR BAG AND SEAT BELT WITH PRE-TENSIONER

M2521000700112

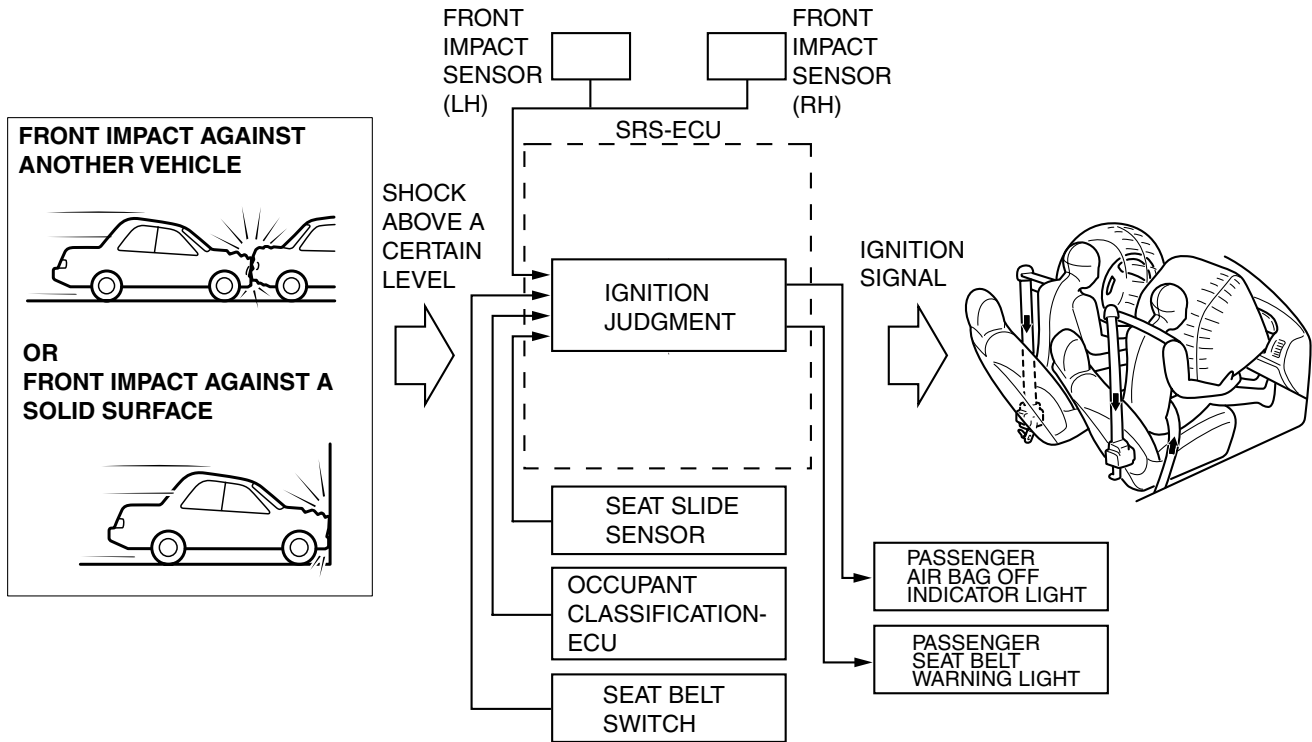

AC306416AC

In case of a frontal collision, if the SRS-ECU and the front air bag safing G-sensor simultaneously detect an impact that based on criteria (turn ON), the SRS-ECU sends an ignition signal to the air bag modules (squibs) and seat belt pre-tensioners (squibs) on the driver and passenger sides, thus inflating the air bags and operating the seat belt pre-tensioners.

SIDE AND CURTAIN AIR BAGS

M2521000800090

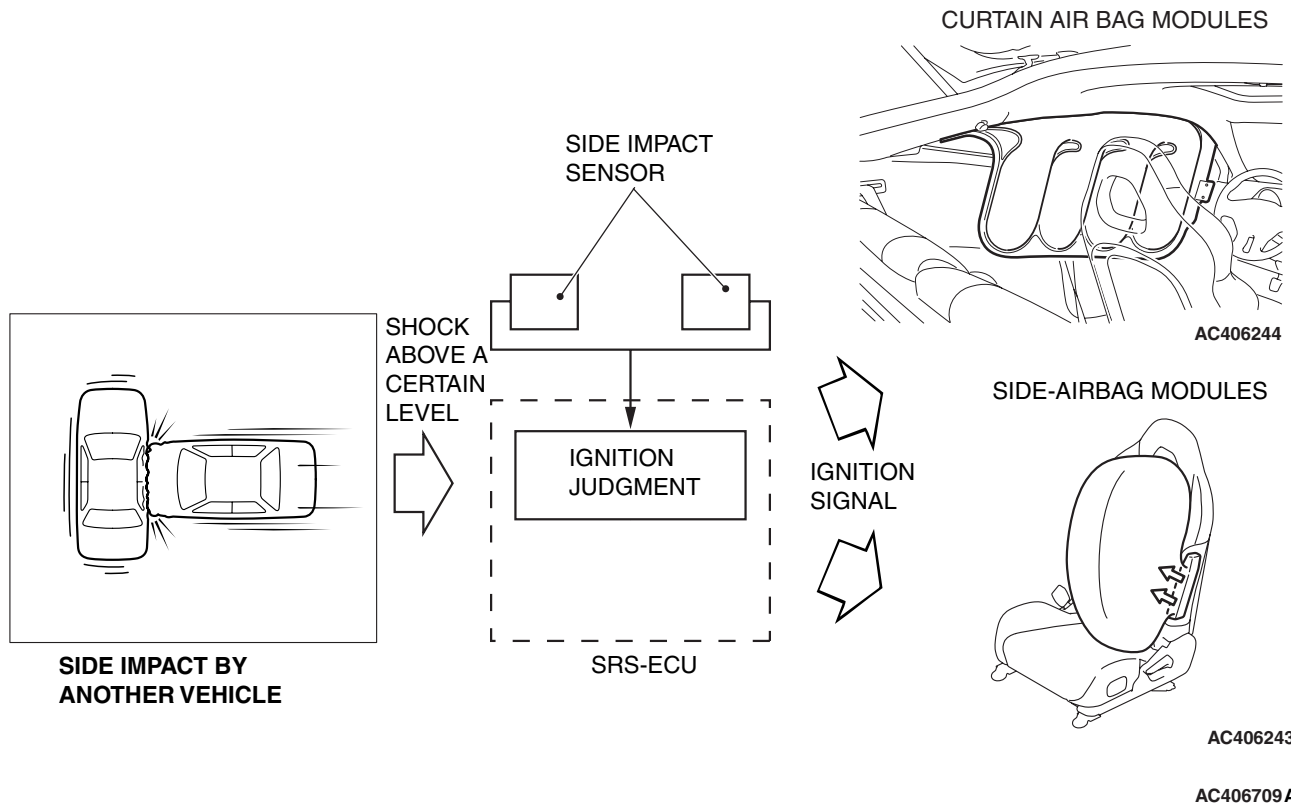

In case of a side collision, if an impact that meets criteria is simultaneously detected by the side impact sensors installed in a center pillar and respectively by the side-airbag safing G-sensor (the sensors turn ON), the SRS-ECU sends an ignition signal to the side-airbag module and curtain air bag module on the relevant side to inflate them.

## SYSTEM CONSTRUCTION

### DRIVER'S AIR BAG MODULE

M2521002000249

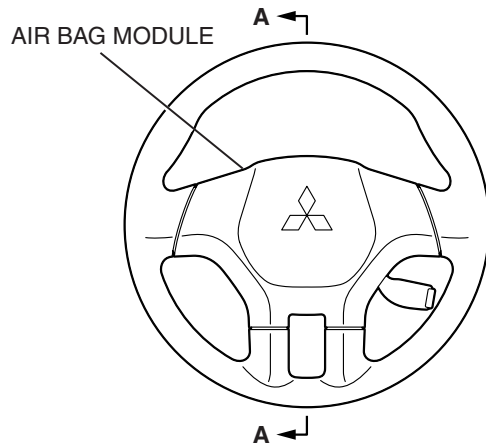

SECTION A - A

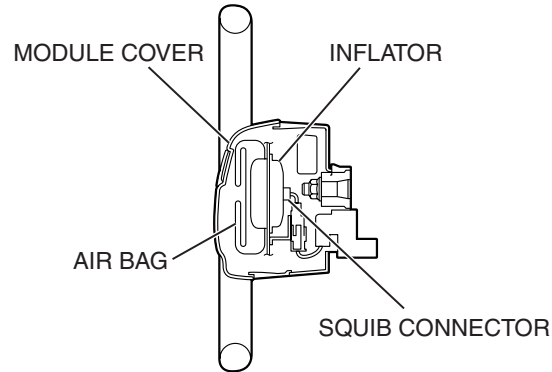

AC406139AB

**CAUTION**

Improper servicing may cause sudden operation of the driver's air bag module or the system to be inoperative.

**WARNING**

***Do not disassemble or tamper with the air bag module. Serious injury may result.***

The driver's air bag module incorporates a 4-spoke steering wheel. The driver's air bag module is an assembly part consisting of an air bag, module cover, inflator, and their fasteners. The air bag is made from nylon and inflates by gas from the inflator. As a driver is being pressed to the air bag, it deflates, discharging gas from two vents at the rear of the air bag to reduce the shock from the impact.

The driver's air bag deploys by changing its inflation pressure in two steps.

The inflator has two squib connectors to deploy the air bag in two steps.

## FRONT PASSENGER'S AIR BAG MODULE

M2521003000220

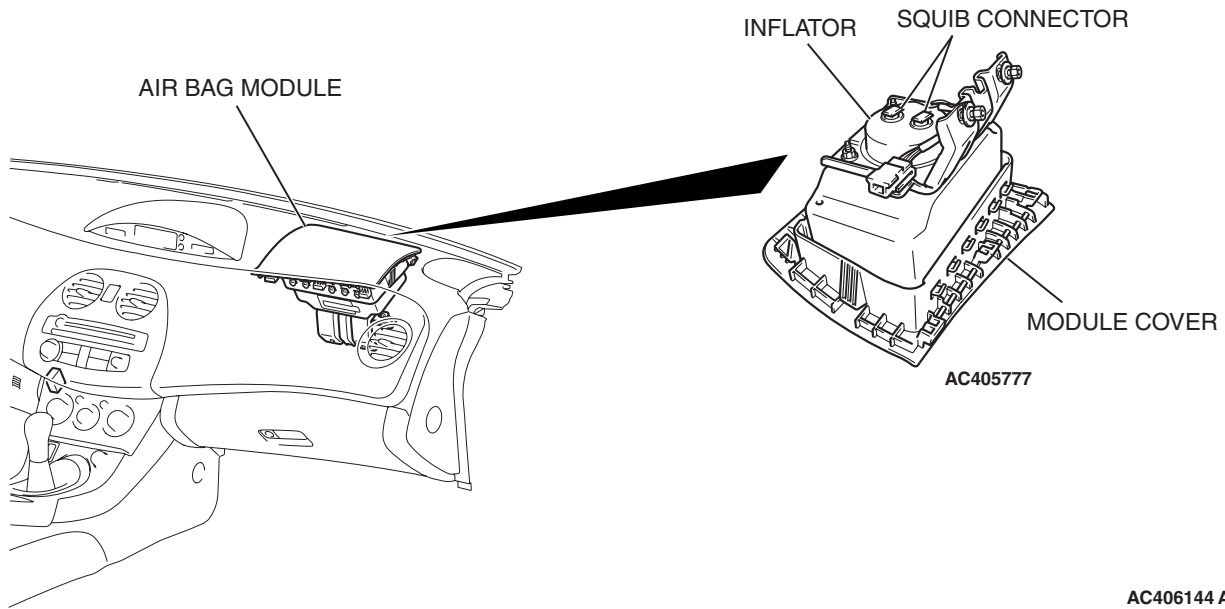

AC406144 AB

**⚠ CAUTION**

Improper servicing may cause sudden operation of the front passenger's air bag module or the system to be inoperative.

**⚠ WARNING**

***Do not disassemble or tamper with the air bag module. Serious injury may result.***

The front passenger's air bag module consists of an air bag, inflator, module cover, and their fasteners.

The air bag is made from nylon and inflates by the gas from the inflator. As a passenger is being pressed to the air bag, it deflates, discharging gas from two vent holes at the side of the air bag to reduce the shock from the impact. The front passenger's air bag deploys by changing its inflation pressure in two steps. The inflator has two squib connector to deploy the air bag in two steps. The front passenger air bag does not deploy at the front passenger seat is not occupied and when the occupant classification sensor in the front passenger seat senses a weight on the seat of less than 30 kg (66 pounds).

SIDE AIR BAG MODULE

M2521004000171

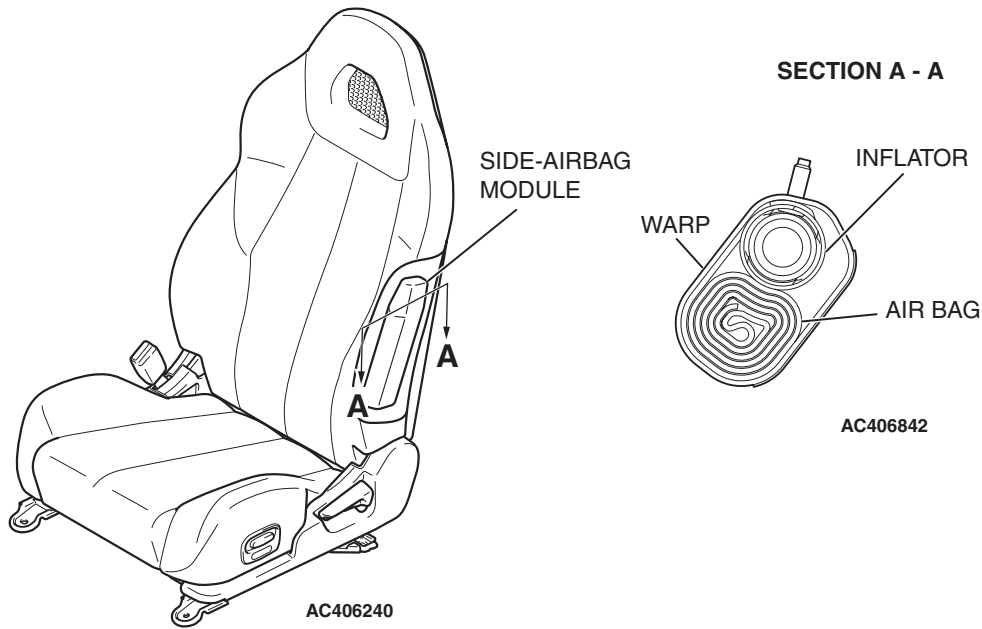

AC406689 AB

**CAUTION**

Improper servicing may cause sudden operation of side-airbag module or the system to be inoperative.

**WARNING**

**Do not disassemble or tamper with the air bag module. Serious injury may result.**

The side-airbag module consists of an air bag, air bag cover, inflator and their fasteners. The modules are installed in the outer side supports of the driver's and front passenger's seatbacks. The side-airbags help protect the occupants regardless of the seat position and seatback angle.

The side-airbags are made of nylon fabric. The side air bags are folded and installed in the warp. On the side of the air bags, there are holes through which gas is partially released to alleviate shock to the occupant when the air bag is deployed.

## CURTAIN AIR BAG MODULE

M2521000500118

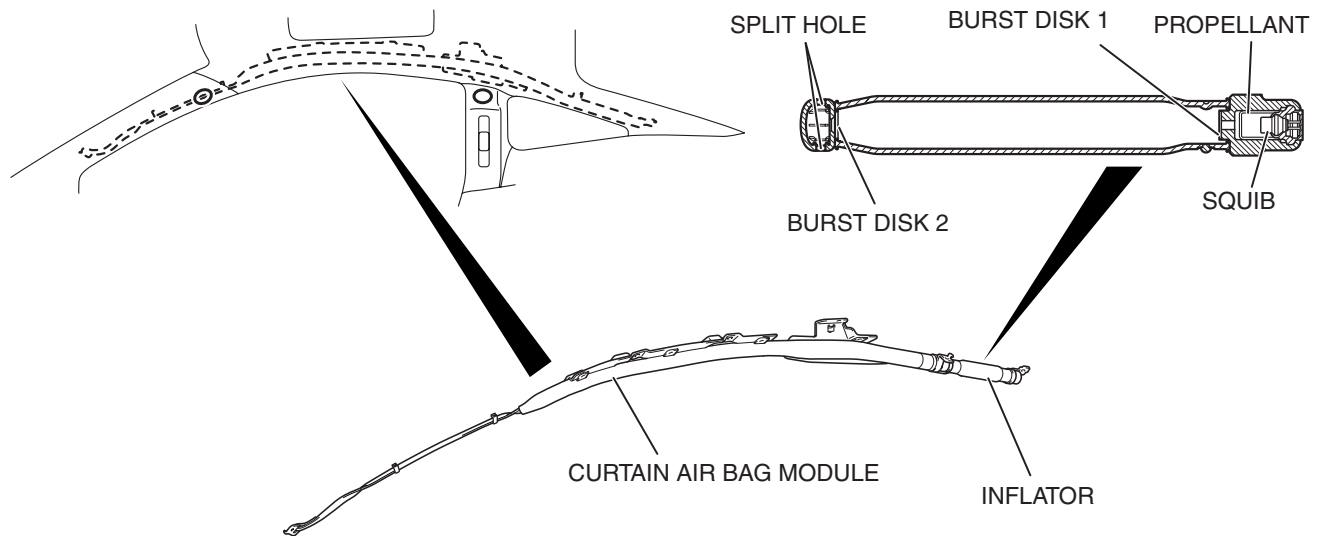

AC406419AB

The curtain air bag module consists of an air bag, an inflator, and the fixing gear relating to those parts, and is installed in the roof side sections (from the driver's and the passenger's front pillars to the rear pillars).

The air bag is made from nylon with the inside coated with silicon, and housed in the roof side sections, folded up compactly.

The inflator is of a hybrid type filled with high-pressure gas (major component: argon). When current passes through the squib to ignite the igniter powder, the burst disk bursts, emitting the gas into the air bag.

## CLOCK SPRING

M2521001100038

**CAUTION**

Improper servicing may cause the system to be inoperative.

**WARNING**

**Do not disassemble or tamper with the clock spring. Serious injury may result.**

The clock spring consists of a flat cable, rotator, stator, etc. While this clock spring is essentially the same as before, it does not have a neutral position indication mechanism. Therefore, the clock spring centering procedures are different.

*NOTE: For the clock spring centering procedures, refer to the SERVICE MANUAL.*

FRONT IMPACT SENSOR

M2521005000226

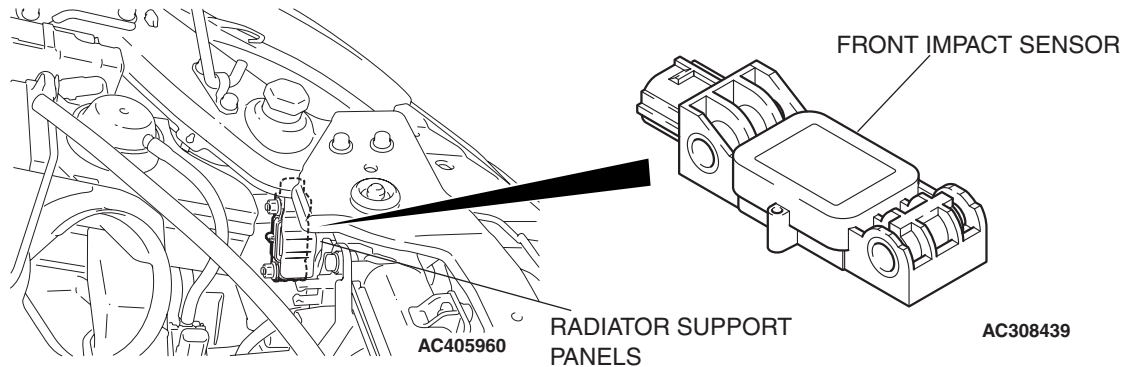

AC406428 AB

**CAUTION**

Improper servicing may cause sudden operation of SRS (air bag) or the system to be inoperative.

**WARNING**

*Do not disassemble or tamper with the front impact sensor. Serious injury may result.*

The front impact sensors are installed on both radiator support panels.

The front impact sensors transmit acceleration data to SRS-ECU. The SRS-ECU then determines whether to operate the driver's air bag, front passenger's air bag and seat belt pre-tensioners, and then outputs an ignition signal when necessary. The front impact sensor also diagnoses itself, and sends a diagnosis code to the SRS-ECU if a problem occurs.

SIDE IMPACT SENSOR

M2521006000207

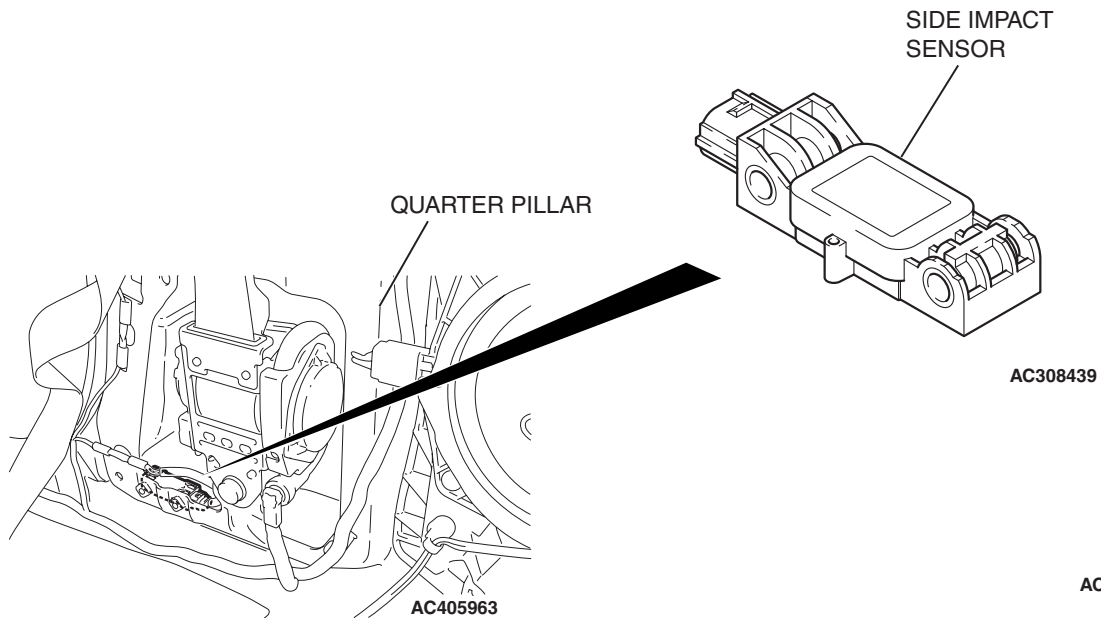

AC406429AB

**CAUTION**

Improper servicing may cause sudden operation of SRS (air bag) or the system to be inoperative.

**WARNING**

*Do not disassemble or tamper with the side impact sensor. Serious injury may result.*

The side impact sensors are installed in the lower part of the center pillar.

The side impact sensors transmit acceleration data to the SRS-ECU. The SRS-ECU then determines if the side air bags should be inflated, and sends an ignition signal. The side impact sensor also diagnoses itself, and sends a diagnosis code to the SRS-ECU if a problem occurs.

## SEAT SLIDE SENSOR

M2521001400051

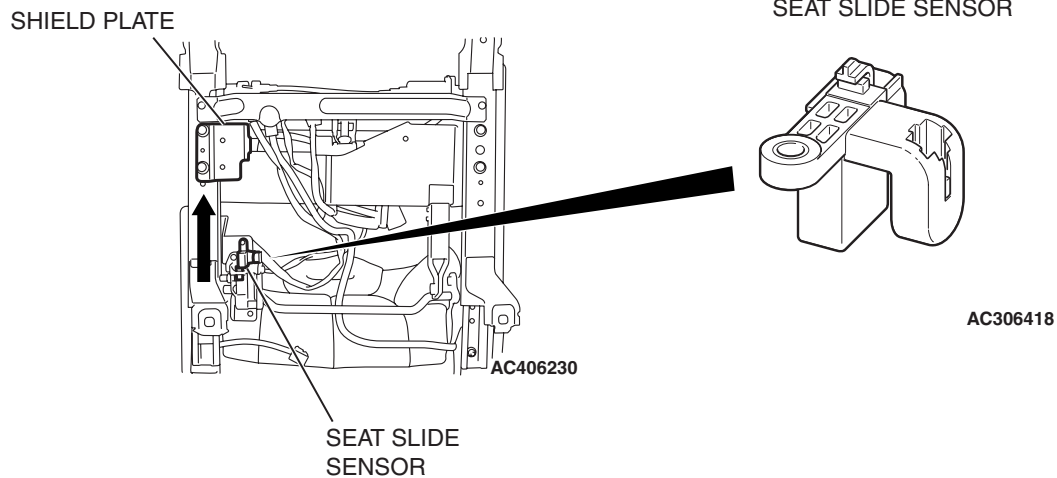

AC406462AB

### **CAUTION**

Improper servicing may cause the system to be inoperative.

### **WARNING**

***Do not disassemble or tamper with the seat slide sensor. Serious injury may result.***

The seat slide sensor is attached to the seat rail and provides the air bag control unit with information on the seat position.

The air bag control unit controls deployment output of the driver's air bag in accordance with the information from the sensor.

OCCUPANT CLASSIFICATION SENSOR

M2521001300021

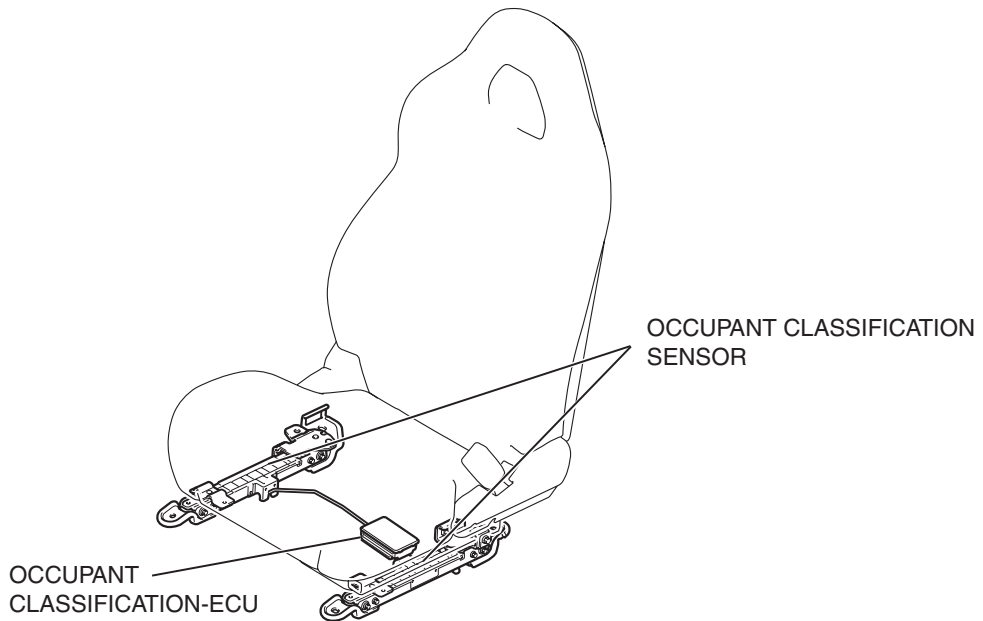

AC406229 AB

**CAUTION**

Improper servicing may cause the system to be inoperative.

**WARNING**

***Do not disassemble or tamper with the occupant classification sensor. Serious injury may result.***

The occupant classification sensors are attached to the seat rails and provide the air bag control unit with information on the weight applied to the front passenger seat.

The air bag control unit controls deployment output of the front passenger's air bag in accordance with the information from the sensor. The front passenger's air bag does not deploy in an impact when the weight applied to the seat is sensed as less than about 30 kg (66 pounds).

SEAT BELT WITH PRE-TENSIONER

M2521008000214

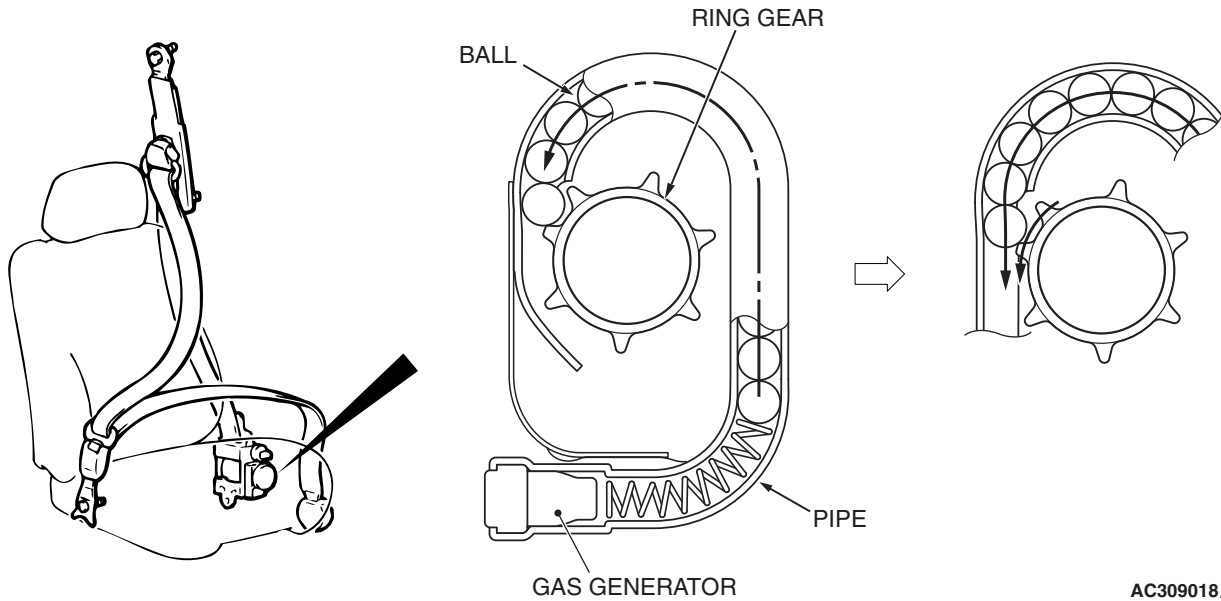

**CAUTION**

Improper servicing may cause sudden operation of the seat belt with pre-tensioner or the system to be inoperative.

**WARNING**

*Do not disassemble or tamper with the seat belt. Serious injury may result.*

The seat belt incorporating the pre-tensioner automatically winds the seat belt upon front impact to reduce forward shifting of the driver and passenger. The seat belt pre-tensioner is built into the driver's and passenger's front seat belt retractor.

Upon front impact, the seat belt pre-tensioner ignites the gas generator and emits gas with the SRS-ECU signal when the front impact sensor and the SRS-ECU detect a gravitational impact at the same time. The gas pressure shifts the ball in the pipe and the balls comes in contact with the protrusion of the ring gear, is inserted in the ring gear. The ring gear rotates to wind the webbing. When the seat belt switch indicates that the seat belt is not worn, the pre-tensioners are deactivated by SRS-ECU.

**PASSENGER SEAT BELT WARNING LIGHT**

M2521001500025

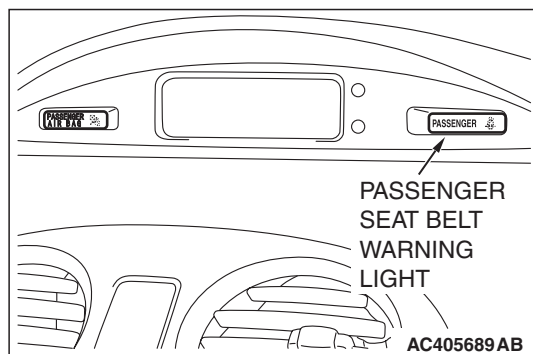

The light normally comes on when the ignition switch is turned to the "ON" position and goes off a few seconds later. The light comes on when a person sits on the front passenger seat but does not fasten the seat belt.

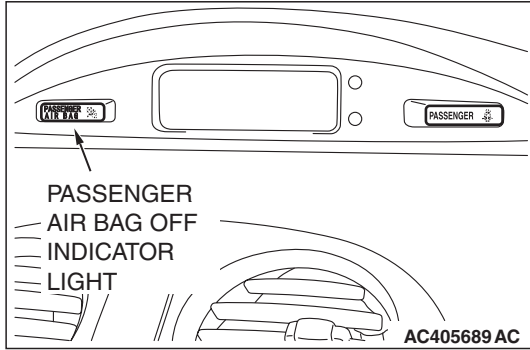

## PASSENGER AIR BAG OFF INDICATOR LIGHT

M2521001600033

The indicator normally comes on when the ignition switch is turned to the "ON" position and goes off a few seconds later. In the following situations, the indicator will stay on to show that the front passenger air bag is not operational.

- The occupant classification sensors sense 30 kg (66 pounds) or less on the front passenger seat.
- The front passenger's seat is not occupied.

When the weight applied to the front passenger seat is sensed as 30 kg (66 pounds) or greater, the indicator goes off to show that the passenger front air bag is operational.

## SRS-ECU

M2521007000363

### **CAUTION**

Improper servicing may cause sudden operation of SRS (air bag) or the system to be inoperative.

### **WARNING**

**Do not disassemble or tamper with the SRS-ECU. Serious injury may result.**

The SRS-ECU incorporates a front analog G-sensor and front safing G-sensor for frontal collisions and a side-airbag safing G-sensor for side collisions. Upon front impact, the SRS-ECU set the ignition signal to the driver's air bag module, the front passenger's air bag module and the seat belt pre-tensioner when the front impact sensor and the SRS-ECU detect a gravitational impact at the same time. Upon side impact, the SRS-ECU set the ignition signal to the side air bag module suffered a impact, when the side impact sensor and the SRS-ECU detect a gravitational impact at the same time.

The SRS-ECU is provided with the following capabilities:

- Backup power supply in case of power failure in collisions
- Self-diagnosis function to avoid system's operation errors and to improve its reliability

## DIAGNOSTIC FUNCTION

The SRS-ECU has the following functions to make system checking easily using the scan tool.

- Diagnostic trouble code output
- Service data output
- Actuator test
- Accuracy check occupant classification sensor

## CAN COMMUNICATION

SRS-ECU, through CAN communication, outputs a signal that requests SRS warning lamp illumination to the meter ECU.

**DIAGNOSTIC TROUBLE CODE OUTPUT**

The SRS-ECU diagnoses the following items and stores a diagnostic trouble code in the non-volatile memory (EEPROM\*<sup>1</sup>) when a problem is detected. Therefore, the memory is not deleted after a battery terminal is disconnected (The diagnostic trouble code memory can be deleted by the scan tool).

<b>CODE NO.</b>	<b>MAJOR CONTENTS OF DIAGNOSTICS</b>
B1400* <sup>3</sup>	Driver's air bag (1st squib) short-circuited
B1401* <sup>3</sup>	Driver's air bag (1st squib) open-circuited
B1402* <sup>3</sup>	Driver's air bag (1st squib) drive circuit (ground side) short-circuited
B1403* <sup>3</sup>	Driver's air bag (1st squib) drive circuit (power supply side) short-circuited
B1404* <sup>4</sup>	Driver's air bag (1st squib) activating circuit short-circuited
B1405* <sup>4</sup>	Driver's air bag (1st squib) activating circuit open-circuited
B1406* <sup>4</sup>	G-sensor of front impact sensor (RH) failure
B1407* <sup>3</sup>	Front impact sensor (RH) voltage error
B1408* <sup>3</sup>	Front impact sensor (RH) communication error
B1409* <sup>3</sup>	Front impact sensor (RH) communication impossible
B1410* <sup>3</sup>	Passenger's (front) air bag (1st squib) short-circuited
B1411* <sup>3</sup>	Passenger's (front) air bag (1st squib) open-circuited
B1412* <sup>3</sup>	Passenger's (front) air bag (1st squib) drive circuit (ground side) short-circuited
B1413* <sup>3</sup>	Passenger's (front) air bag (1st squib) drive circuit (power supply side) short-circuited
B1414* <sup>4</sup>	Passenger's (front) air bag (1st squib) activating circuit short-circuited
B1415* <sup>4</sup>	Passenger's (front) air bag (1st squib) activating circuit open-circuited
B1416* <sup>4</sup>	G-sensor of front impact sensor (LH) failure
B1417* <sup>3</sup>	Front impact sensor (LH) voltage error
B1418* <sup>3</sup>	Front impact sensor (LH) communication error
B1419* <sup>3</sup>	Front impact sensor (LH) communication impossible
B1420* <sup>3</sup>	Side-airbag squib (RH) short-circuited
B1421* <sup>3</sup>	Side-airbag squib (RH) open-circuited
B1422* <sup>3</sup>	Side-airbag squib (RH) drive circuit (ground side) shorted
B1423* <sup>3</sup>	Side-airbag squib (RH) drive circuit (power supply side) shorted
B1424* <sup>4</sup>	Side-airbag squib (RH) activating circuit short-circuited
B1425* <sup>4</sup>	Side-airbag squib (RH) activating circuit open-circuited
B1426* <sup>4</sup>	G-sensor of side impact sensor (RH) failure
B1427* <sup>3</sup>	Side impact sensor (RH) voltage error
B1428* <sup>3</sup>	Side impact sensor (RH) communication error

<b>CODE NO.</b>	<b>MAJOR CONTENTS OF DIAGNOSTICS</b>
B1429 <sup>*3</sup>	Side impact sensor (RH) communication impossible
B1430 <sup>*3</sup>	Side-airbag squib (LH) short-circuited
B1431 <sup>*3</sup>	Side-airbag squib (LH) open-circuited
B1432 <sup>*3</sup>	Side-airbag squib (LH) drive circuit (ground side) shorted
B1433 <sup>*3</sup>	Side-airbag squib (LH) drive circuit (power supply side) shorted
B1434 <sup>*4</sup>	Side-airbag squib (LH) activating circuit short-circuited
B1435 <sup>*4</sup>	Side-airbag squib (LH) activating circuit open-circuited
B1436 <sup>*4</sup>	G-sensor of side impact sensor (LH) failure
B1437 <sup>*3</sup>	Side impact sensor (LH) voltage error
B1438 <sup>*3</sup>	Side impact sensor (LH) communication error
B1439 <sup>*3</sup>	Side impact sensor (LH) communication impossible
B1440 <sup>*3</sup>	Curtain air bag squib (RH) short-circuited
B1441 <sup>*3</sup>	Curtain air bag squib (RH) open-circuited
B1442 <sup>*3</sup>	Curtain air bag squib (RH) drive circuit (ground side) shorted
B1443 <sup>*3</sup>	Curtain air bag squib (RH) drive circuit (power supply side) shorted
B1444 <sup>*4</sup>	Curtain air bag squib (RH) activating circuit short-circuited
B1445 <sup>*4</sup>	Curtain air bag squib (RH) activating circuit open-circuited
B1450 <sup>*3</sup>	Curtain air bag squib (LH) short-circuited
B1451 <sup>*3</sup>	Curtain air bag squib (LH) open-circuited
B1452 <sup>*3</sup>	Curtain air bag squib (LH) drive circuit (ground side) shorted
B1453 <sup>*3</sup>	Curtain air bag squib (LH) drive circuit (power supply side) shorted
B1454 <sup>*4</sup>	Curtain air bag squib (LH) activating circuit short-circuited
B1455 <sup>*4</sup>	Curtain air bag squib (LH) activating circuit open-circuited
B1460 <sup>*3</sup>	Seat belt pre-tensioner (RH) squib short-circuited
B1461 <sup>*3</sup>	Seat belt pre-tensioner (RH) squib open-circuited
B1462 <sup>*3</sup>	Seat belt pre-tensioner (RH) squib (ground side) short-circuited
B1463 <sup>*3</sup>	Seat belt pre-tensioner (RH) squib (power supply side) short-circuited
B1464 <sup>*4</sup>	Seat belt pre-tensioner (RH) activating circuit short-circuited
B1465 <sup>*4</sup>	Seat belt pre-tensioner (RH) activating circuit open-circuited
B1466 <sup>*4</sup>	Analog G-sensor malfunction
B1467 <sup>*4</sup>	Safing G-sensor open-circuited (for frontal collision)
B1468 <sup>*4</sup>	Safing G-sensor short-circuited (for frontal collision)
B1469 <sup>*4</sup>	Safing G-sensor malfunction (for side collision)
B1470 <sup>*3</sup>	Seat belt pre-tensioner (LH) squib short-circuited

CODE NO.	MAJOR CONTENTS OF DIAGNOSTICS	
B1471 <sup>*3</sup>	Seat belt pre-tensioner (LH) squib open-circuited	
B1472 <sup>*3</sup>	Seat belt pre-tensioner (LH) squib drive circuit (ground side) short-circuited	
B1473 <sup>*3</sup>	Seat belt pre-tensioner (LH) squib drive circuit (power supply side) short-circuited	
B1474 <sup>*4</sup>	Seat belt pre-tensioner (LH) activating circuit short-circuited	
B1475 <sup>*4</sup>	Seat belt pre-tensioner (LH) activating circuit open-circuited	
B1476 <sup>*2</sup>	Power supply voltage (IG1 (A) voltage) drops abnormally.	
B1477 <sup>*2</sup>	Power supply voltage (IG1 (B) voltage) drops abnormally.	
B1478 <sup>*4</sup>	SRS-ECU capacitor circuit voltage too high	
B1479 <sup>*4</sup>	SRS-ECU capacitor circuit voltage too low	
B1480 <sup>*3</sup>	Driver's air bag (2nd squib) short-circuited	
B1481 <sup>*3</sup>	Driver's air bag (2nd squib) open-circuited	
B1482 <sup>*3</sup>	Driver's air bag (2nd squib) drive circuit (ground side) short-circuited	
B1483 <sup>*3</sup>	Driver's air bag (2nd squib) drive circuit (power supply side) short-circuited	
B1484 <sup>*4</sup>	Driver's air bag (2nd squib) activating circuit short-circuited	
B1485 <sup>*4</sup>	Driver's air bag (2nd squib) activating circuit open-circuited	
B1486 <sup>*4</sup>	Seat belt warning light circuit malfunction	
B1487 <sup>*3</sup>	Seat belt warning light circuit open-circuited	Light does not illuminate <sup>*2</sup>
		Light does not switch off
B1488 <sup>*4</sup>	Air bag OFF indicator light circuit malfunction	
B1489 <sup>*3</sup>	Air bag OFF indicator light circuit open-circuited	Light does not illuminate <sup>*2</sup>
		Light does not switch off
B1490 <sup>*3</sup>	Passenger's (front) air bag (2nd squib) short-circuited	
B1491 <sup>*3</sup>	Passenger's (front) air bag (2nd squib) open-circuited	
B1492 <sup>*3</sup>	Passenger's (front) air bag (2nd squib) drive circuit (ground side) short-circuited	
B1493 <sup>*3</sup>	Passenger's (front) air bag (2nd squib) drive circuit (power supply side) short-circuited	
B1494 <sup>*4</sup>	Passenger's (front) air bag (2nd squib) activating circuit short-circuited	
B1495 <sup>*4</sup>	Passenger's (front) air bag (2nd squib) activating circuit open-circuited	
B1496 <sup>*4</sup>	SRS-ECU non-volatile memory (EEPROM <sup>*1</sup> )	
B1497 <sup>*4</sup>	SRS-ECU application specific integrated circuit (for frontal activation)	
B1498 <sup>*4</sup>	SRS-ECU ROM or RAM	
B1499 <sup>*4</sup>	Collision Decision	
B1506 <sup>*3</sup>	Seat slide sensor circuit open	
B1507 <sup>*3</sup>	Seat slide sensor circuit (ground side) shorted	
B1508 <sup>*3</sup>	Seat slide sensor circuit (power supply side) shorted	

<b>CODE NO.</b>	<b>MAJOR CONTENTS OF DIAGNOSTICS</b>
B1509*2	Incorrect SRS-ECU
B1519*3	SRS-ECU connector lock out of order
B1520*3	Seat belt switch (RH) malfunction
B1521*3	Seat belt switch (RH) circuit open (for Normal/Close terminal)
B1522*3	Seat belt switch (RH) circuit (ground side) shorted (for Normal/Close terminal)
B1523*3	Seat belt switch (RH) circuit (power supply side) shorted (for Normal/Close terminal)
B1524*3	Seat belt switch (RH) circuit open (for Normal/Open terminal)
B1525*3	Seat belt switch (RH) circuit (ground side) shorted (for Normal/Open terminal)
B1526*3	Seat belt switch (RH) circuit (power supply side) shorted (for Normal/Open terminal)
B1527*3	Seat belt switch (RH) circuit open (for common terminal)
B1528*3	Seat belt switch (RH) circuit (ground side) shorted (for common terminal)
B1529*3	Seat belt switch (RH) circuit (power supply side) shorted (for common terminal)
B1530*3	Seat belt switch (LH) malfunction
B1531*3	Seat belt switch (LH) circuit open (for Normal/Close terminal)
B1532*3	Seat belt switch (LH) circuit (ground side) shorted (for Normal/Close terminal)
B1533*3	Seat belt switch (LH) circuit (power supply side) shorted (for Normal/Close terminal)
B1534*3	Seat belt switch (LH) circuit open (for Normal/Open terminal)
B1535*3	Seat belt switch (LH) circuit (ground side) shorted (for Normal/Open terminal)
B1536*3	Seat belt switch (LH) circuit (power supply side) shorted (for Normal/Open terminal)
B1537*3	Seat belt switch (LH) circuit open (for common terminal)
B1538*3	Seat belt switch (LH) circuit (ground side) shorted (for common terminal)
B1539*3	Seat belt switch (LH) circuit (power supply side) shorted (for common terminal)
B1540*3	Occupant classification-ECU malfunction
B1541*3	Occupant classification-ECU calibration malfunction
B1542*3	Occupant classification sensor (S1) malfunction
B1543*3	Occupant classification sensor (S2) malfunction
B1545*3	Occupant classification-ECU communication error
B1546*3	Occupant classification-ECU communication impossible
B1548*3	CAN communication impossible
B1549*3	CAN communication error
B1552*4	Changing circuit shorted
B1553*4	Changing circuit open
B1554*4	SG BY-PASS circuit malfunction
B1555*4	SG BY-PASS circuit (field effect transistor) open

CODE NO.	MAJOR CONTENTS OF DIAGNOSTICS
B1556*3	Seat slide sensor malfunction
B1557*4	SRS-ECU application specific integrated circuit
B1558*3	Occupant classification-ECU ID-cord malfunction
U1073*2	Bus-off

NOTE: \*1: Electrically Erasable Programmable ROM

\*2: This DTC will remain in memory and the SRS warning light will be switched off when the system returns to normal condition.

\*3: This DTC will remain in memory and the SRS warning light will be switched on even if the system returns to normal condition.

\*4: This DTC cannot be erased by "Erase DTCs" function.

## DATA LIST OUTPUT

The data input from all sensors and switches can be read using the scan tool.

NO.	DATA LIST ITEM	CHECK CONDITIONS	NORMAL CONDITIONS
1	Failure continuation time 1	Always	Maximum time to be stored: 9,999 minutes (approximately seven days)
2	Failure continuation time 2	Always	
3	Elimination times	Always	Maximum time to be stored: 255 days
4	Driver seat belt (Buckle SW1)	Wear the driver seat belt.	Unfastened/Fastened
5	Passenger seat belt (Buckle SW1)	Wear the passenger seat belt.	Unfastened/Fastened
6	Driver seat belt (Buckle SW2)	Undo the driver seat belt.	Fastened/Unfastened
7	Passenger seat belt (Buckle SW2)	Undo the passenger seat belt.	Fastened/Unfastened
8	Driver seat air bag Ignition	Do not apply any load to the driver seat.	Permission/Prohibition
9	Passenger seat air bag Ignition	Do not apply any load to the passenger seat.	Permission/Prohibition
10	Driver seat position	Slide the seat from the back-end position to the front-end position.	Rear/Front
11	Occupant classification	Apply a load to the passenger seat.	Class 0/Class 1/Class 2/Not Clear/–
12	OCSS* parts number	Always	–
13	Occupant weight	Apply a load to the passenger seat.	kg/Unknown

NOTE: \*: Occupant Classification Sensing System

**ACTUATOR TEST**

The scan tool can be used to forcibly operate the next actuator.

MUT-III SCAN TOOL DISPLAY	ITEM NO.	ITEM	PARTS TO BE ACTIVATED
SRS warning light	1	The SRS warning light illuminates.	CAN output
Passenger seat belt warn. light	2	Seat belt warning light illumination	SRS-ECU output
Passenger SRS OFF light	3	Air bag-OFF indicator light illumination	

**ACCURACY CHECK OCCUPANT CLASSIFICATION SENSOR**

- Seat Weight Sensor Accuracy Check
- Zero-calibration

The scan tool can be used to perform the next function.

**SRS AIR BAG SPECIAL CONNECTOR**

M2521009000251

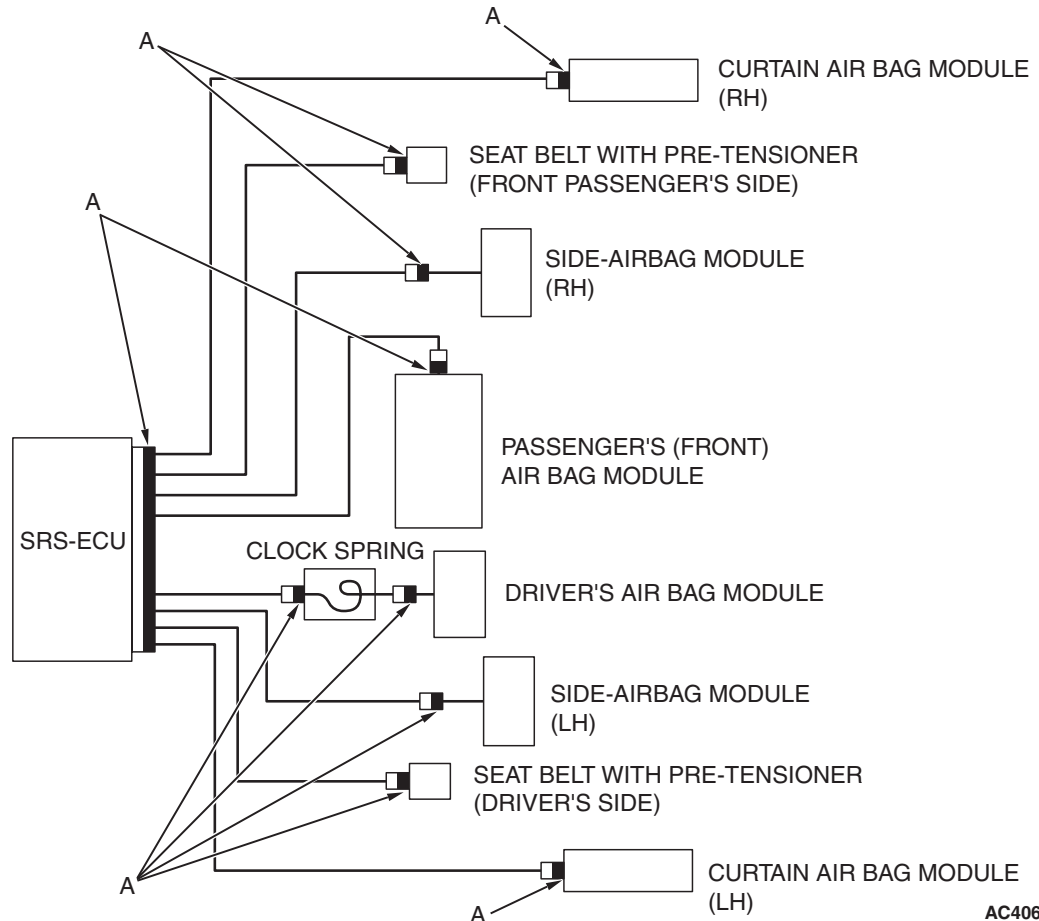

A connector engagement check mechanism is used. A connector lock switch is integrated in the SRS-ECU connector, the air bag module connectors, the clock spring connector and the seat belt pre-tensioner connectors (black connector "A" shown in the illustration above).

## SQUIB CIRCUIT CONNECTOR LOCK SWITCH

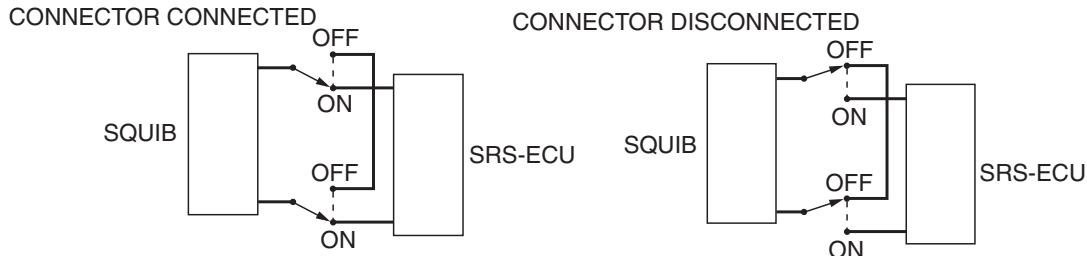

<CONNECTOR SHORTING MECHANISM (E. G. SRS-ECU CONNECTOR)>

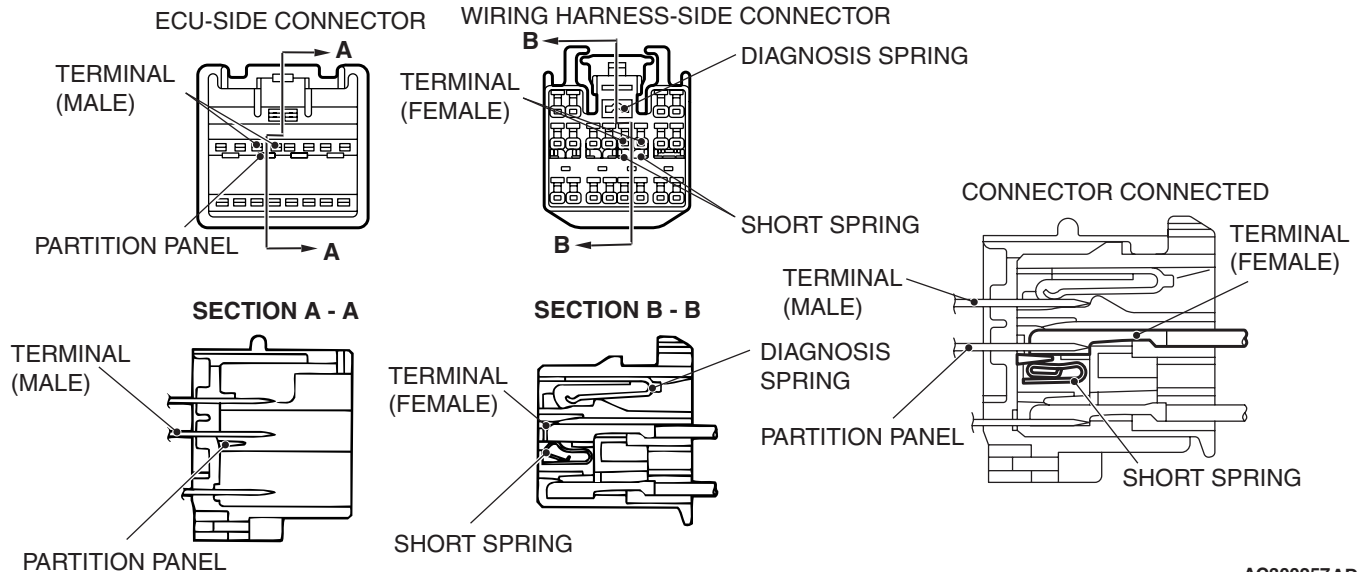

AC300257 AD

**CAUTION**

When the connector is disconnected, it is normal for short-circuiting to occur between the connector terminals.

- The diagnosis spring is assembled on the SRS-ECU wiring harness-side connector. When the ECU-side connector is connected to the SRS-ECU wiring harness-side connector, the diagnosis spring is disengaged from the terminal to short the circuit between the ECU-side connector terminals. The connector engagement is detected electrically by the monitor to this circuit.

- This mechanism automatically short-circuits the power supply side terminal and ground side terminal of the air bag when the connector is disconnected. A short spring is incorporated in the connector to short-circuit the power supply side terminal and ground side terminal of the air bag (no potential difference between the two terminals) and prevent flow of current by static electricity to the squib.