

## GROUP 54B

# SIMPLIFIED WIRING SYSTEM (SWS)

## CONTENTS

GENERAL DESCRIPTION.....	54B-2	DIAGNOSTIC FUNCTION .....	54B-7
COMMUNICATION METHOD .....	54B-3	ECU FUNCTIONS AND CONTROLS IN THE SWS .....	54B-10
MULTI-DISTRIBUTION INPUT/OUTPUT BY CIRCUIT .....	54B-4		

## GENERAL DESCRIPTION

M2541000100480

SWS is a minimal line system which transmits numerous signals using one wiring harness to reduce weight and complication of harnesses due to the increase in electronic accessories.

To transmit numerous signals, the ETACS\*<sup>1</sup>-ECU, column switch (incorporating inside the column-ECU), front-ECU and sunroof-ECU incorporate multi-distribution circuits to carry out communication between control units.

The ECLIPSE also makes use of CAN\*<sup>2\*3</sup>communications for even better functionality.

\*<sup>1</sup>ETACS:Electronic Time and Alarm Control System

\*<sup>2</sup>CAN:Controller Area Network

\*<sup>3</sup> : For details on CAN, see Group 54C.

## CONSTRUCTION DIAGRAM

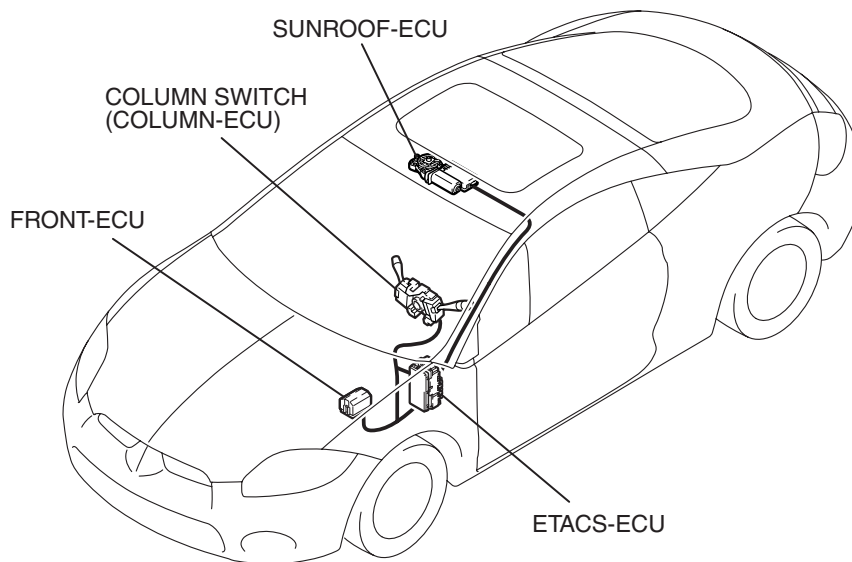

AC405905AB

## COMMUNICATION METHOD

M2541001000390

As shown in the figure, SWS communications connect the ETACS-ECU, the column switch (in the column-ECU), the front-ECU, and the sunroof-ECU. CAN communications connect the ETACS-ECU, the engine control module <M/T>, the powertrain control

module <A/T>, the A/C-ECU, the SRS-ECU, the combination meter, the ABS-ECU <vehicles without TCL> and the ABS/TCL-ECU <vehicles with TCL>. These two communications groups are connected to form a dedicated network for sending multiplex data.

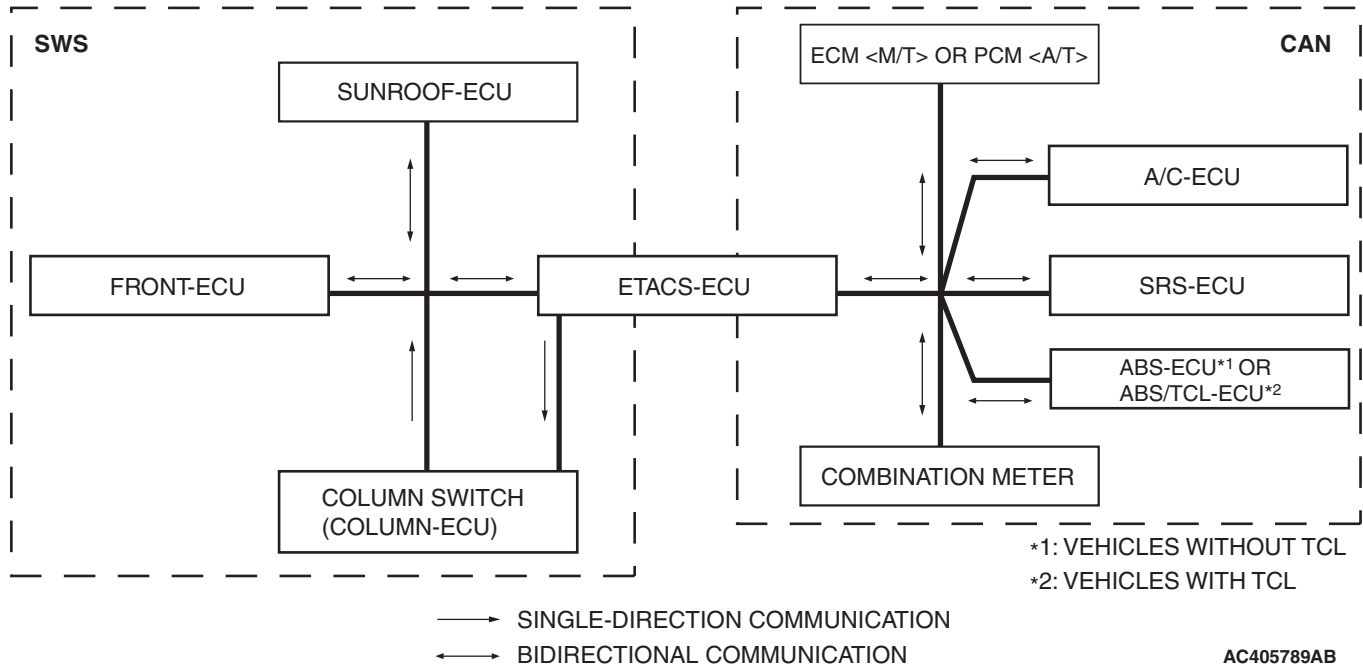

AC405789AB

# MULTI-DISTRIBUTION INPUT/OUTPUT BY CIRCUIT

M2541002000467

Multi-distribution is employed by the following circuits. The relation of the input switches, sensors, ECUs connected by multi-distribution lines, and outputs are also shown below.

### Tone alarm

- Ignition key reminder tone alarm function
- Lights still ON reminder warning function
- Seat belt tone alarm function
- Door ajar tone alarm function

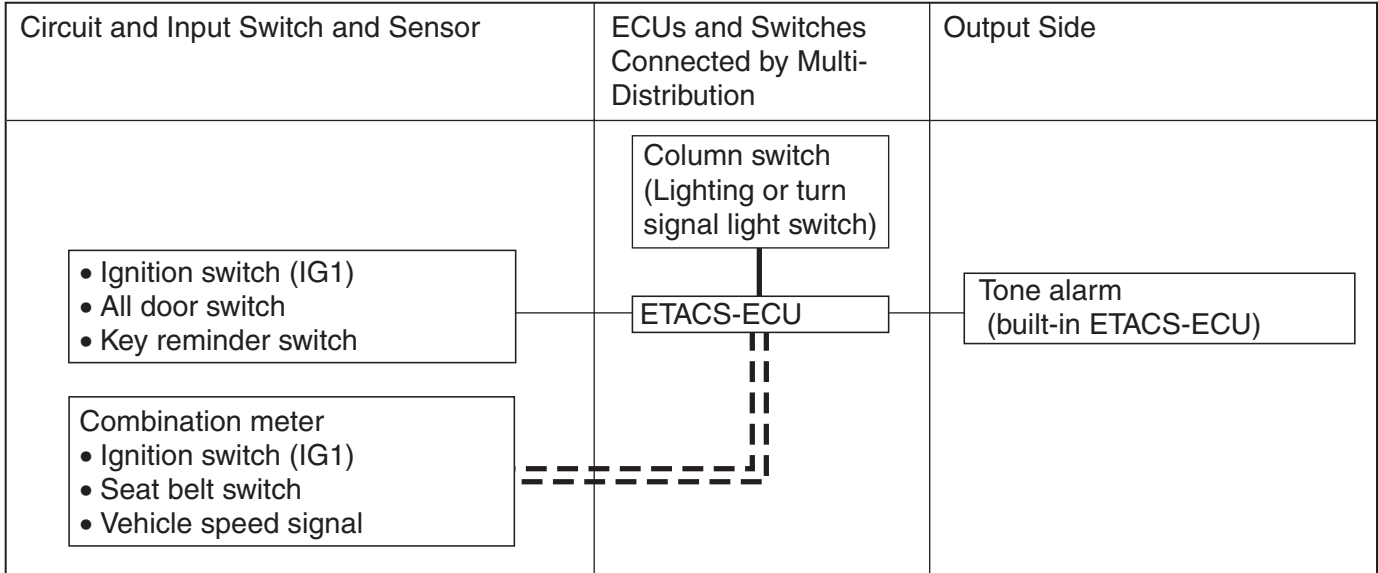

— : SWS communication line

=== : CAN communication line

AC405790AB

**Windshield wiper washer**

- Windshield mist wiper
- Vehicle speed-dependent variable windshield intermittent wiper
- Windshield low-speed wiper
- Windshield high-speed wiper
- Windshield washer

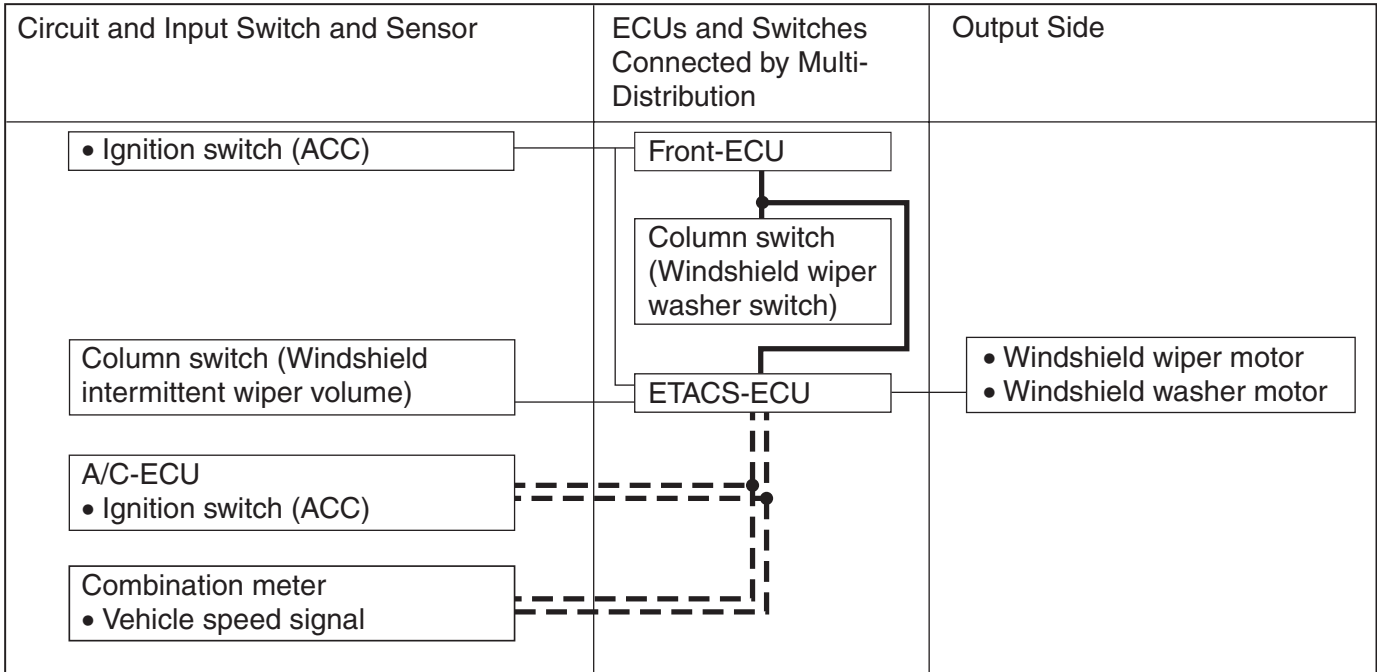

— : SWS communication line  
 - - - : CAN communication line

AC405791 AB

**Rear wiper washer**

- Rear wiper
- Rear washer

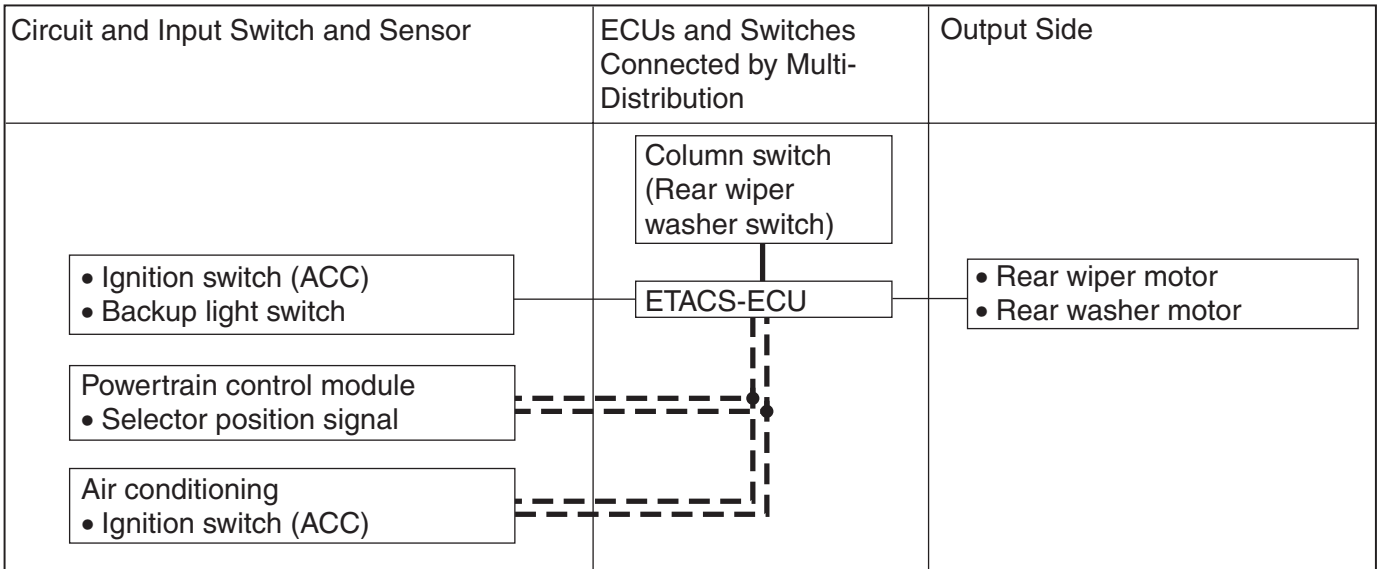

— : SWS communication line  
 - - - : CAN communication line

AC404791AB

**Lighting**

- Headlight, taillight
- Headlight automatic shutoff function
- Front fog light
- Daytime running light

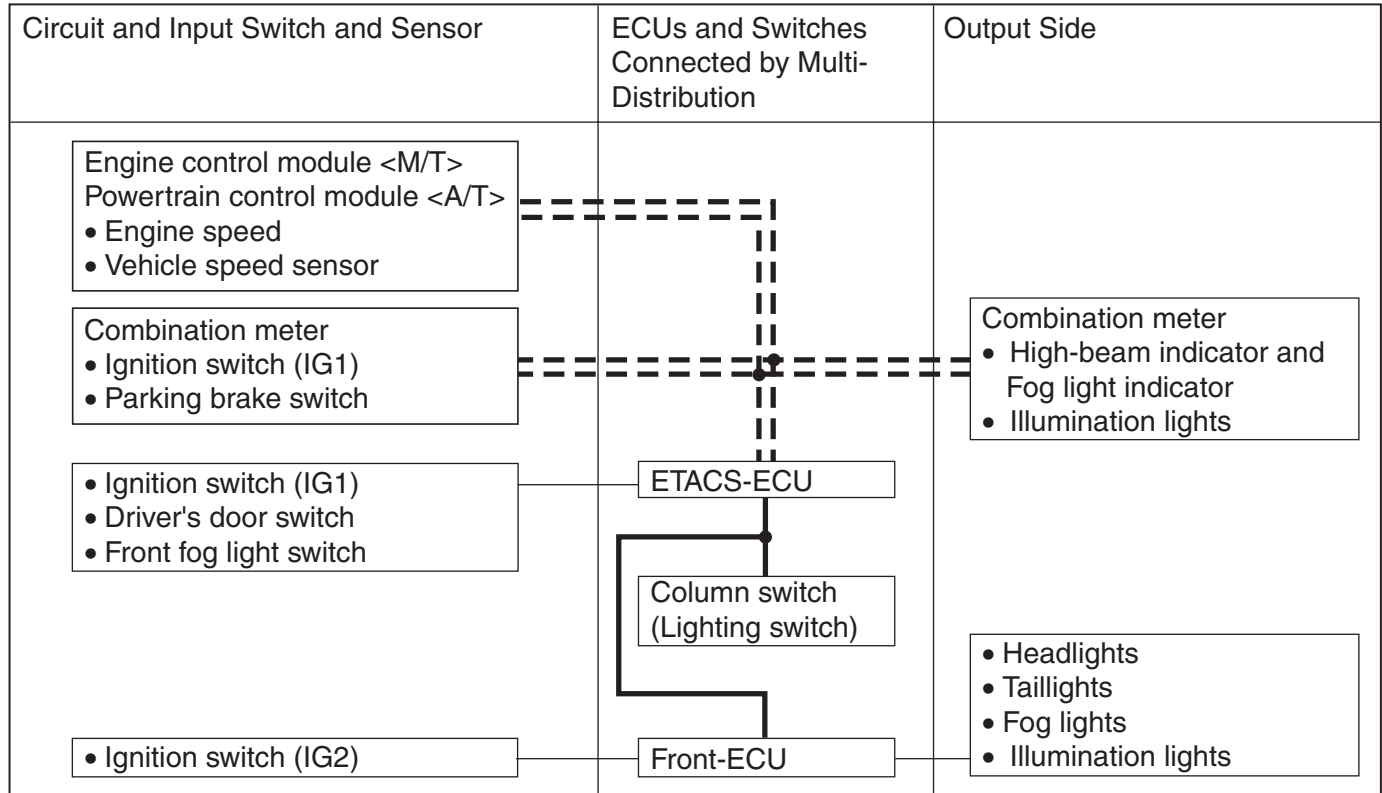

— : SWS communication line  
 - - - : CAN communication line

AC404797 AB

**Flasher**

- Turn signal light
- Hazard warning light

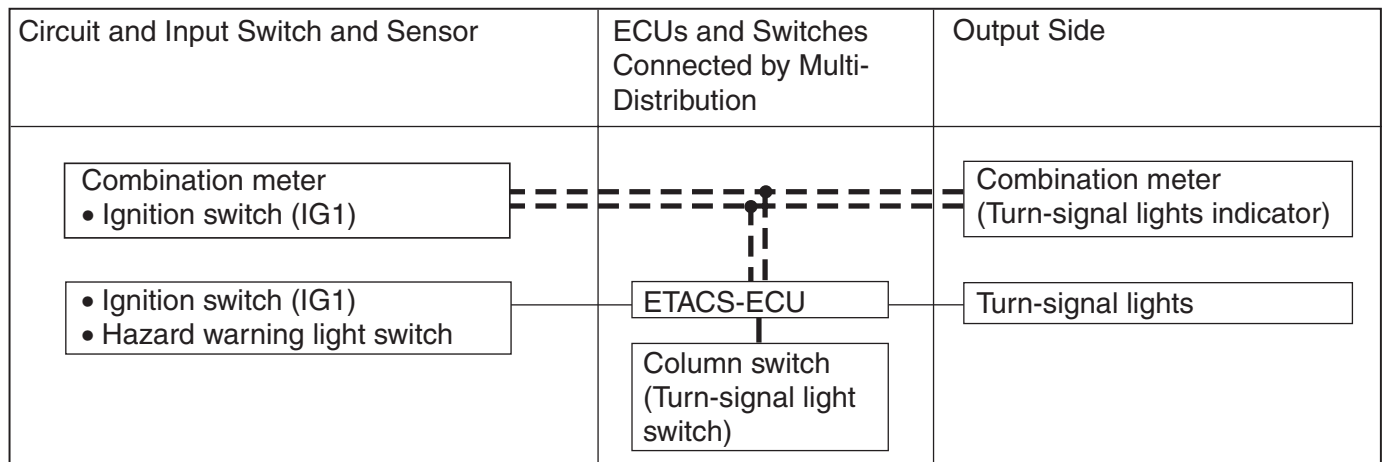

— : SWS communication line  
 - - - : CAN communication line

AC305317 AC

**Sunroof**

- Sunroof timer function

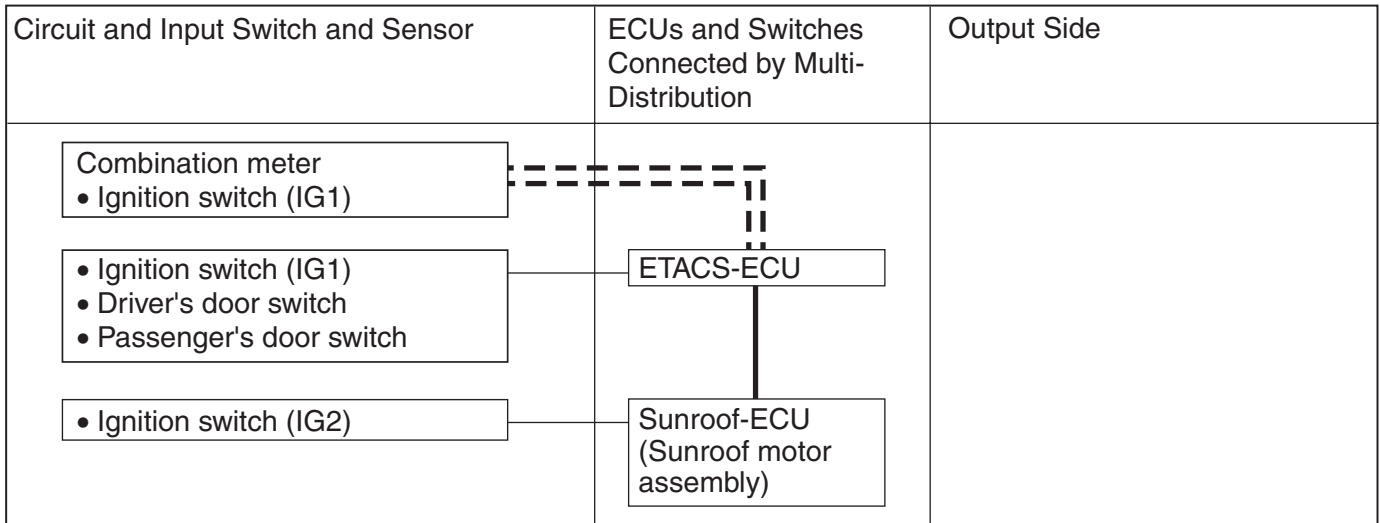

— : SWS communication line

≡≡≡ : CAN communication line

AC305318AB

## DIAGNOSTIC FUNCTION

M2541003000437

### DIAGNOSTIC TROUBLE CODE SET

If there is a problem with the communication line, the ETACS-ECU sends a diagnosis code when the scan tool (MUT-III) is connected.

*NOTE: \*1: For vehicles that do not have a sunroof, the diagnosis code is always sent but it does not indicate a problem.*

*NOTE: \*2: The diagnostic trouble code is always set, but it does not indicate a problem.*

*NOTE: \*3: The diagnosis code for the past problem is not sent.*

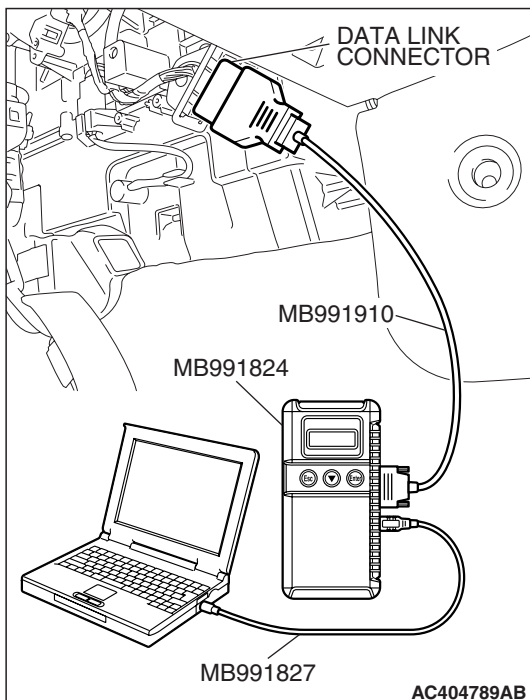

AC404789AB

CODE NUMBER	TROUBLE CONTENT
U1700	Malfunction in the SWS communication line
U1701	Communication error in the column switch
U1702	Communication error in the front-ECU
U1703*1	Communication error in the sunroof-ECU or the sunroof not installed
U1704*2	Communication error in the power window main switch
U1073	Bus Off
U1100	Engine control module <M/T> or powertrain control module <A/T> time-out (related to engine)

CODE NUMBER	TROUBLE CONTENT
U1101	Engine control module <M/T> or powertrain control module <A/T> time-out (related to transaxle)
U1108	Combination meter time-out
U1110	A/C-ECU time-out
U1111* <sup>2</sup>	Multi center display unit (middle-grade type) time-out
U1128	Failure information on combination meter
B1702* <sup>3</sup>	Reception error of transponder data
B1703* <sup>3</sup>	Transponder data inconsistent
B1731	Immobilizer communication failure.
B1761	VIN not recorded

## SWS INPUT SIGNAL CHECK BY SCAN TOOL

While performing a "Pulse Check" with the MUT-III, the computer buzzer will sound when the switches shown in the table below are operated.

### INPUT SIGNALS THAT CAN BE CHECKED

INPUT SIGNAL	CONDITION FOR SOUNDING TONE ALARM
Ignition switch (ACC)	Turn from "LOCK" (OFF) to "ACC" position
Ignition switch (IG1)	Turn from "ACC" to "ON" position
Key reminder switch	Remove the ignition key from ignition key cylinder (form inserted position)
Hazard warning light switch	Turn from OFF to ON
Front fog light switch	
Driver's or front passenger's door switch	Open the door
Door lock key cylinder switch	Turn the key to the lock or unlock position
Driver's or front passenger's door lock actuator switch	Move the door lock knob from lock position to unlock position
Door lock switch (incorporated in power window main switch and power window sub switch)	Press "LOCK" or "UNLOCK" side
Liftgate latch switch	Open the liftgate
Backup light switch <M/T>	When the shift lever is moved to the R position
Rear wiper auto stop signal	When the rear wiper is operated
Liftgate lock release switch	When the liftgate lock release switch is operated

<b>INPUT SIGNAL</b>		<b>CONDITION FOR SOUNDING TONE ALARM</b>
Column switch	Taillight switch	When the lighting switch is turned from one position to the taillight position
	Headlight switch	When the lighting switch is turned from one position to the headlight position
	Dimmer switch	When the switch is turned from the OFF to the ON position
	Passing switch	
	Turn-signal light LH switch	
	Turn-signal light RH switch	
	Windshield mist wiper switch	
	Windshield intermittent wiper switch	
	Windshield low speed wiper switch	
	Windshield high speed wiper switch	
	Variable intermittent wiper control switch	When turned from FAST to SLOW (A pulse is output around the center)
	Windshield washer switch	When the switch is turned from the OFF to the ON position
	Rear wiper switch	
	Rear washer switch	
Interior light loaded signal		Illuminates the interior lights
Transmission range switch ("R" position) <A/T> (CAN signal)		When the selector lever is moved to the R position
Parking brake switch (CAN signal)		When the parking brake is pulled
Vehicle speed signal (CAN signal)		When the vehicle speed displayed on the meter has reached 8km/h (5 mph) or more
Driver's seat belt switch (CAN signal)		When the seat belt is fastened.

## ECU FUNCTIONS AND CONTROLS IN THE SWS

The SWS has the following functions and system controls:

FUNCTION		CONTROL ECU	FUNCTION DESCRIPTION
Tone alarm	Ignition key reminder tone alarm function	ETACS-ECU	P.54B-11
	Light reminder tone alarm function	ETACS-ECU, column switch	P.54B-11
	Seat belt tone alarm function	ETACS-ECU	P.54B-11
	Door ajar tone alarm function		P.54B-13
Central door locking system	Door unlocking by operating the driver's door lock key cylinder	ETACS-ECU	P.54B-14
	Door locking or unlocking by operating the driver's or passenger's door lock switch		P.54B-14
	Forgotten key prevention function		P.54B-15
Power window	Power window timer function	ETACS-ECU	P.54B-16
Keyless entry system	Keyless entry hazard answerback function	ETACS-ECU	P.54B-17
	Keyless entry horn answerback function		P.54B-17
	Liftgate unlock function		P.54B-17
	Timed locking mechanism		P.54B-17
Sunroof	Sunroof timer function	ETACS-ECU, sunroof-ECU	P.54B-17
Windshield wiper and washer	Intermittent control (Vehicle speed-dependent variable type)	ETACS-ECU, front-ECU, column switch	P.54B-18
	Mist wiper control		P.54B-18
	Low speed wiper, high speed wiper control		P.54B-19
	Washer control		P.54B-19
Rear wiper and washer	Rear wiper control	ETACS-ECU, column switch	P.54B-20
	Rear washer control		P.54B-20
Headlights and taillights	Taillights	ETACS-ECU, front-ECU, column switch	P.54B-21
	Headlights		P.54B-21
	Headlight automatic-shutoff function		P.54B-22
	High-beam indicator		P.54B-22
	Daytime running light function		P.54B-22
Flasher timer	Turn-signal lights	ETACS-ECU, front-ECU, column switch	P.54B-23
	Hazard warning light		P.54B-23
	Turn-signal indicators		P.54B-24
Front fog light	Front fog light	ETACS-ECU, front-ECU, column switch	P.54B-24
	Front fog light indicator		P.54B-24

FUNCTION		CONTROL ECU	FUNCTION DESCRIPTION
Interior light	Interior light control	ETACS-ECU	<a href="#">P.54B-25</a>
	Interior light automatic-shutoff function		<a href="#">P.54B-25</a>
	Seat belt indicator		<a href="#">P.54B-26</a>
	Door ajar indicator		<a href="#">P.54B-27</a>
	Ignition key cylinder illumination function		<a href="#">P.54B-28</a>
Panic alarm system		ETACS-ECU	Refer to Group 54A, Panic Alarm System <a href="#">P.54A-16</a>

## TONE ALARM

### IGNITION KEY REMINDER TONE ALARM FUNCTION

When the driver's door is opened with the ignition key inserted in the ignition key cylinder (ignition switch is in the OFF position,) the tone alarm sounds intermittently to indicate that the ignition key has not been removed.

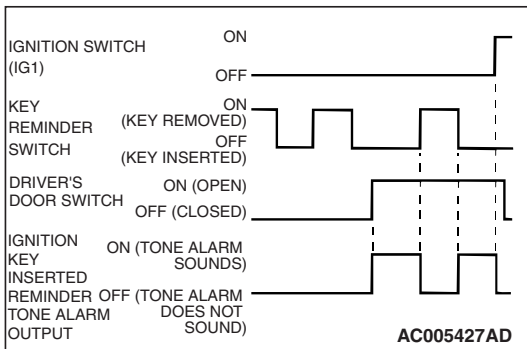

### LIGHT REMINDER TONE ALARM FUNCTION

When the taillights or headlights are ON, if the ignition key is removed and the driver's door is opened, a tone alarm will sound continuously to warn that the lights are on. However, if the taillights or headlights have been turned off by the headlight automatic-shutoff function, the tone alarm will not sound.

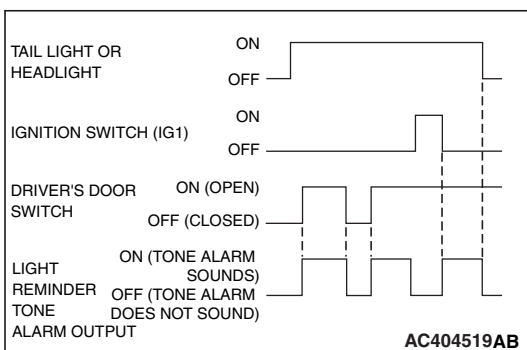

### Seat belt tone alarm function

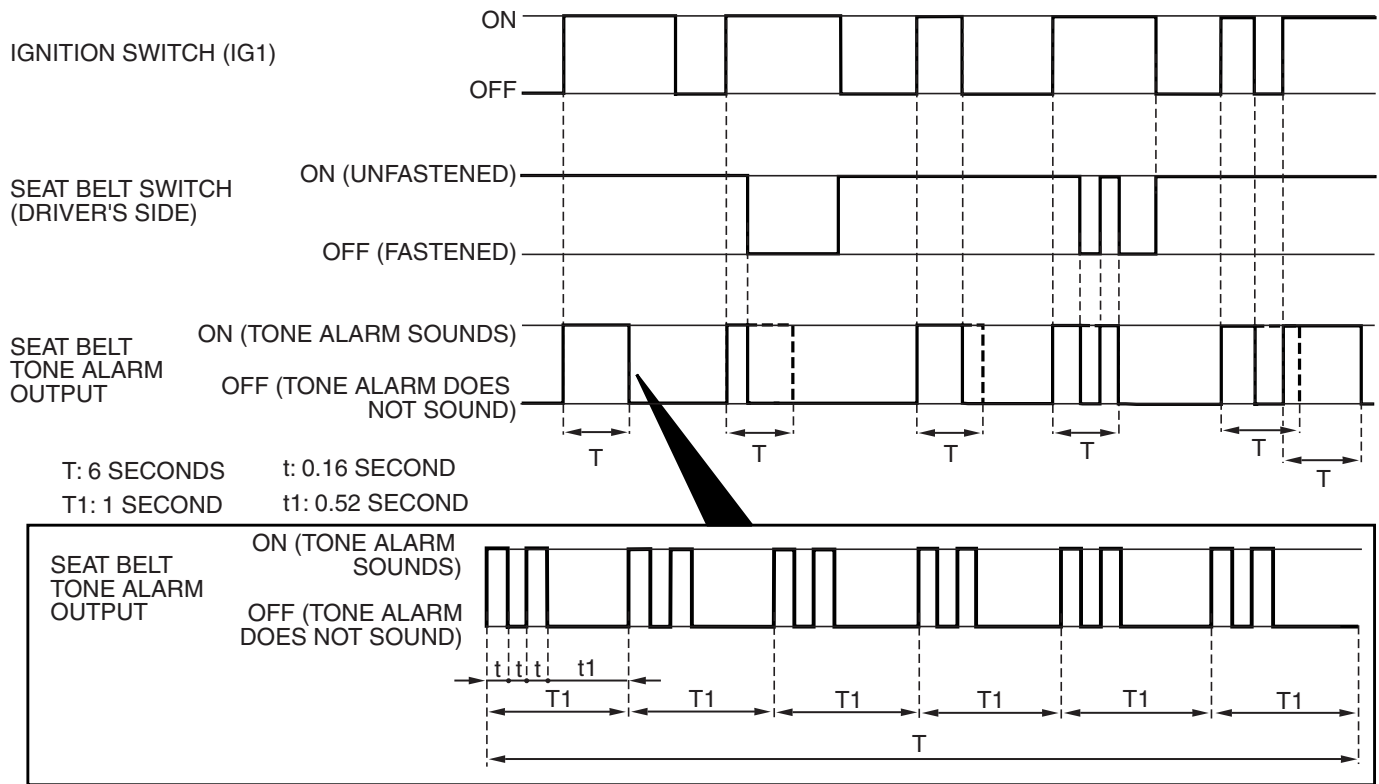

AC305326 AC

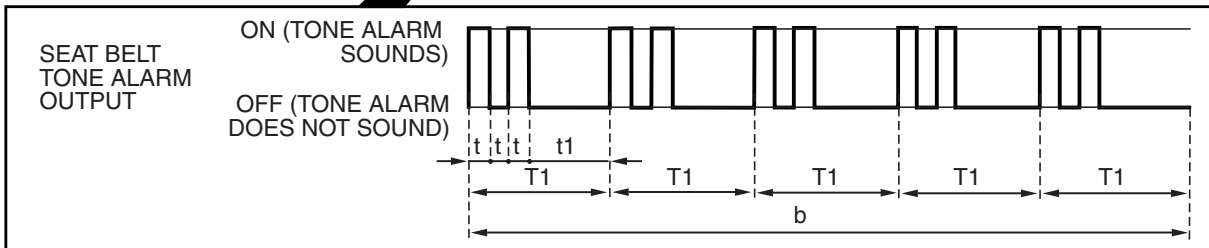
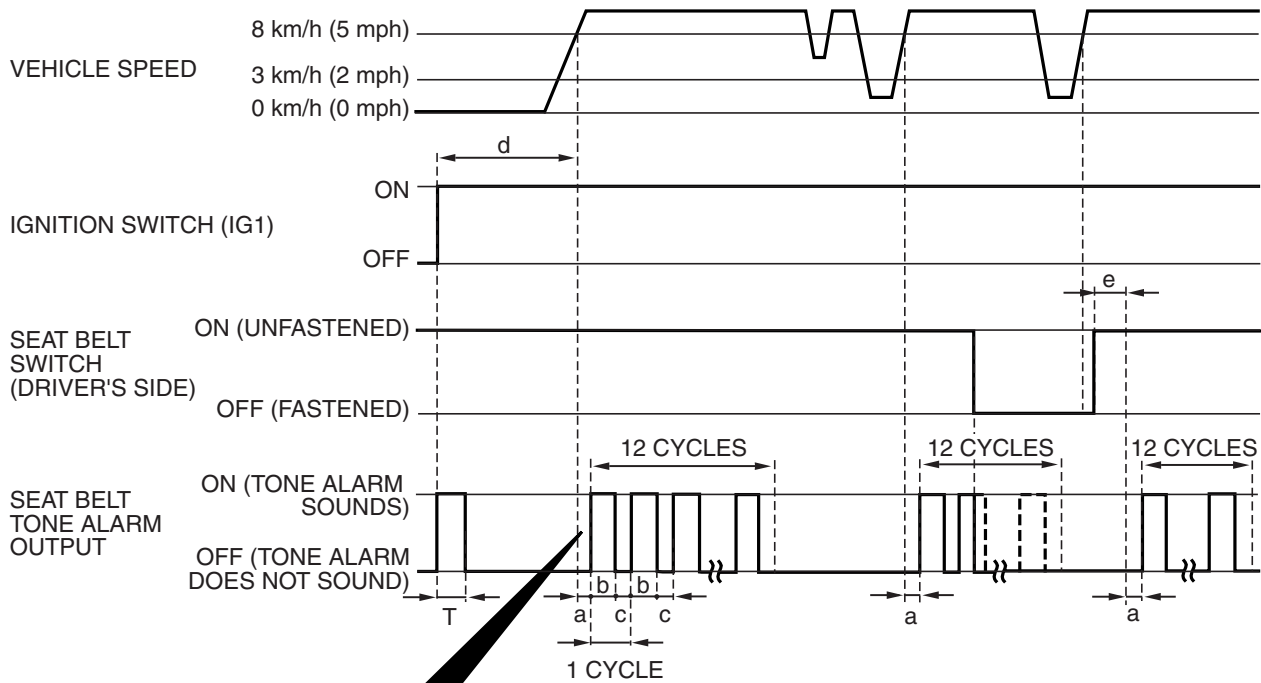

T: 6 SECONDS      t: 0.16 SECOND      a: 0.5 SECOND      c: 3 SECONDS      e: 10 SECONDS  
 T1: 1 SECOND      t1: 0.52 SECOND      b: 5 SECONDS      d: 60 SECONDS OR MORE      AC500126AB

If any of the following conditions are met with the ignition switch at "ON" or "ST", the ETACS-ECU sounds the tone alarm by using the driver's seat belt switch signal and the vehicle speed signal from the combination meter.

- Sounds the tone alarm for 6 seconds when the ignition switch is turned "ON" with the seat belt switch on (the driver's seat belt is not fastened) (Timer function).
- Sounds the tone alarm 12 cycles (after 0.5 second) if any of the following conditions are met when 60 seconds or more have elapsed since the ignition switch is turned "ON". One cycle consists of 5 seconds "on" and then 3 seconds "off".

- The vehicle speed has reached 8 km/h (5 mph) while the seat belt switch is turned on (driver's seat belt is not fastened) with the ignition switch "ON".
- The seat belt switch has been turned on (driver's seat belt has not been fastened) for at least 10 seconds while the ignition switch has been turned "ON" and the vehicle speed has been 8 km/h (5 mph) or more.

*NOTE: Once the tone alarm has sounded 12 cycles, it does not sound again until the vehicle speed reduces to 3 km/h (2 mph) or less even if any of the following conditions is met.*

- The tone alarm stops sounding if the ignition switch or the seat belt switch is turned off (the driver's seat belt is fastened) while the timer operation is active.

**DOOR AJAR TONE ALARM FUNCTION**

The buzzer is sounded 4 times by the ETACS-ECU to warn the driver if any door (including liftgate) is open when the ignition is switched ON and the vehicle speed reaches 8 km/h (5 mph) or faster. The buzzer will continue to sound 4 times even if the ignition, door status, or vehicle speed requirements are not maintained.

**CENTRAL DOOR LOCKING SYSTEM**

**DOOR UNLOCKING BY OPERATING THE DRIVER'S DOOR LOCK KEY CYLINDER**

When the ignition key is inserted in the driver's door lock key cylinder and turned clockwise to unlock the driver's door, the ETACS-ECU operates its door unlock relay and passes a current through the door lock actuator of the driver's door for 0.25 second to unlock only the driver's door.

When the ignition key is turned clockwise again, the ETACS-ECU operates its door unlock relay and passes a current through the door lock actuators of all doors for 0.25 second to unlock all doors.

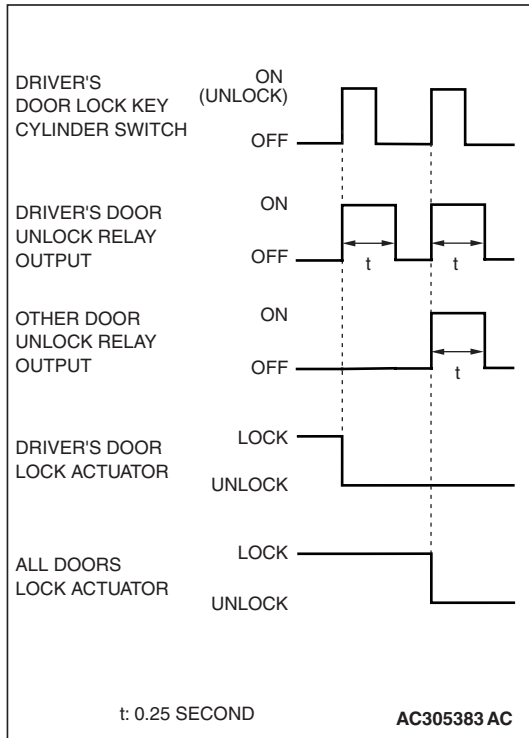

**DOOR LOCKING OR UNLOCKING BY OPERATING THE DRIVER'S OR PASSENGER'S DOOR LOCK SWITCH**

When the door is locked by the driver's or passenger's door lock switch, the ETACS-ECU operates its door lock relay and passes a current through the door lock actuators of all doors for 0.25 second to lock all doors.

When the door is unlocked by the driver's or passenger's door lock switch, the ETACS-ECU operates its door unlock relay and passes a current through the door lock actuators of all doors for 0.25 second to unlock all doors.

When the door is locked and unlocked by driver's or passenger's door lock switch consecutively, the ETACS-ECU operates its door lock relay and passes a current through the door lock actuators of all doors for 0.25 second to lock all doors. Then, the ETACS-ECU operates its door unlock relay and passes a current through the door lock actuators of all doors for 0.25 second to unlock all doors. Due to this, there may be a time lag between the driver's or passenger's door lock switch actuation and the time when all doors are unlocked.

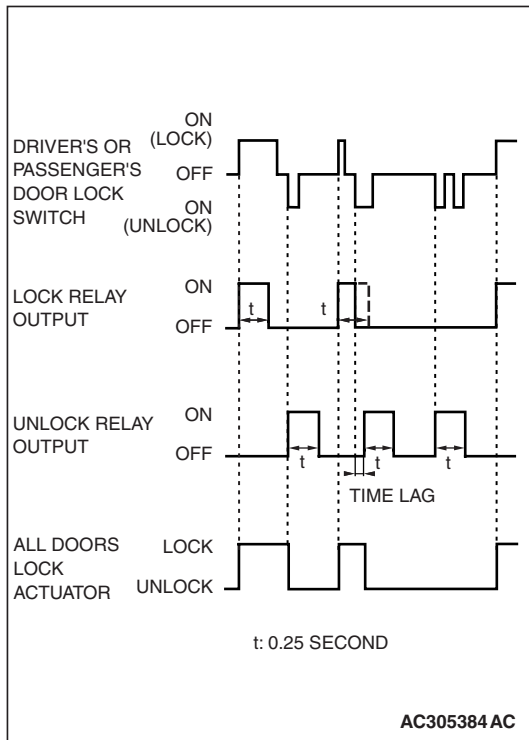

**Forgotten key prevention function**

**If the driver's door is locked while it is open**

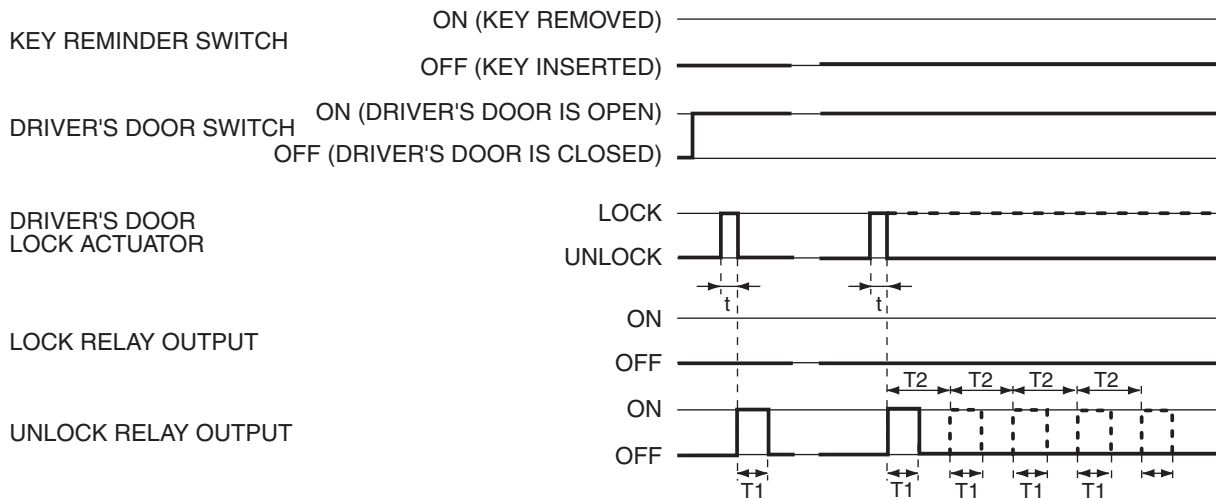

t: 0.3 SECOND  
T1: 0.25 SECOND  
T2: 1 SECOND

If the driver's door is locked while it is open and when the key is still in the ignition key cylinder, approximately 0.3 second later the ETACS-ECU activates the unlock relay output for 0.25 second to prevent the door from being locked with the key inside the vehicle.

In addition, if locking the door was not prevented, a re-try current is sent (an unlock relay output ON is sent for 0.25 second up to 5 times including the first attempt).

*NOTE: The dotted line indicates that the system is trying to turn on the unlock relay if the door cannot be unlocked.*

If the passenger's door is open when it is locked with the driver's door switch

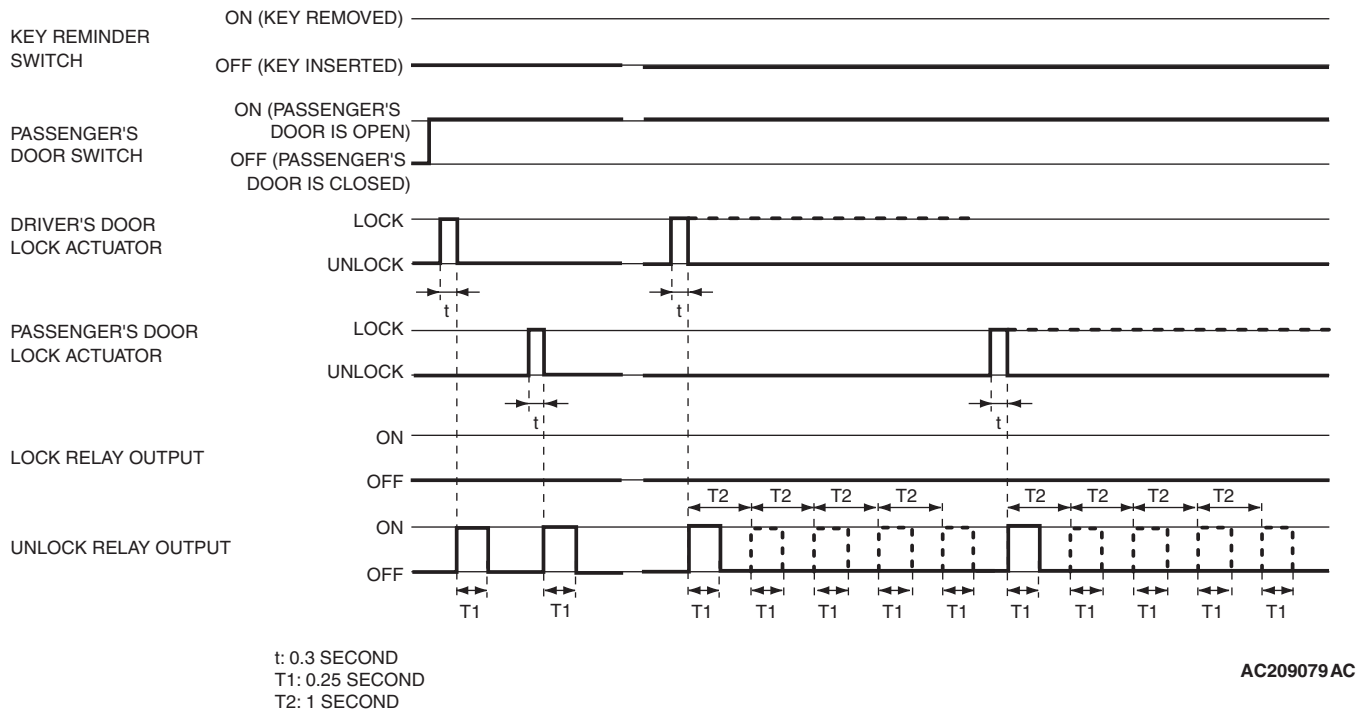

If the passenger's door or driver's door are locked while the passenger's door is open and when the key is still in the ignition key cylinder, approximately 0.3 second later the ETACS-ECU activates the unlock relay output for 0.25 second to prevent the door from being locked with the key inside the vehicle.

In addition, if locking the door was not prevented, a re-try current is sent (an unlock relay output ON is sent for 0.25 second up to 5 times including the first attempt).

*NOTE: The dotted line indicates that the system is trying to turn on the unlock relay if the door cannot be unlocked.*

**POWER WINDOW**

**POWER WINDOW TIMER FUNCTION**

Even after the ignition is switched off, the ETACS-ECU keeps the power window relay activated for approximately 30 seconds, enabling raising or lowering of the power windows by using the power window switches. After approximately 30 seconds, the power window relay is deactivated.

During this timed operation, if the driver's or passenger's doors are opened, the power window relay is deactivated from that moment.

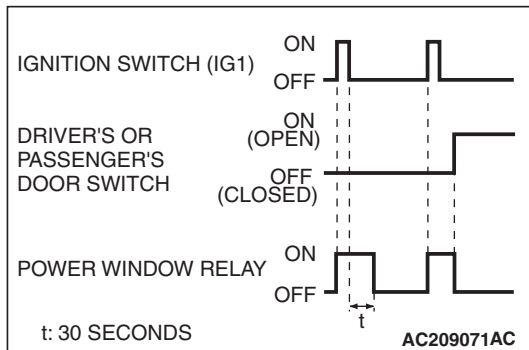

## KEYLESS ENTRY SYSTEM

### KEYLESS ENTRY HAZARD ANSWERBACK FUNCTION\*

If the keyless entry transmitter is used to send a lock signal to the ETACS-ECU, all doors are locked and the hazard warning lights flash once. If an unlock signal is sent, the driver's door is unlocked first, and if a second signal is sent, all doors are unlocked. Each time the unlock signal is sent, the hazard warning lights flash twice.

*NOTE: \* The hazard answerback function can be customized using the keyless entry transmitter (Refer to Group 42 P.42-13).*

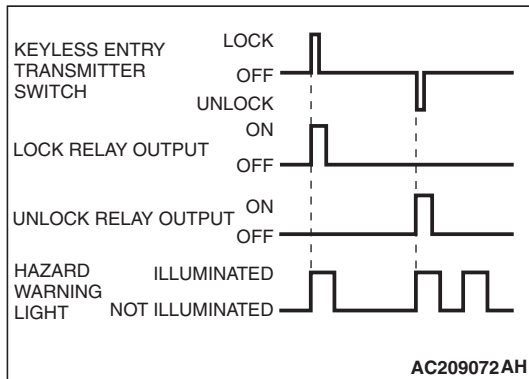

### KEYLESS ENTRY HORN ANSWERBACK FUNCTION

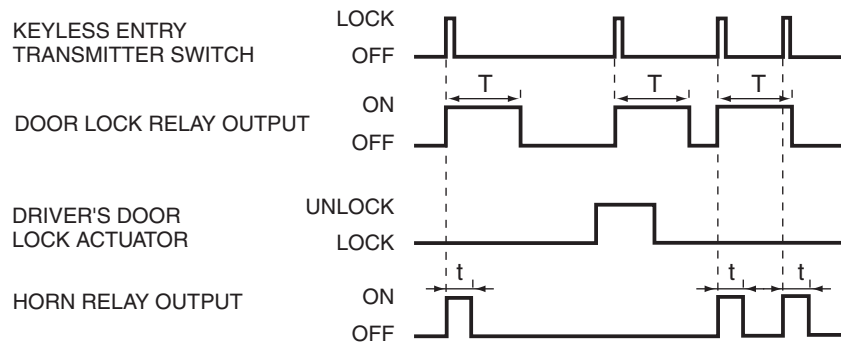

t: 0.15 SECOND  
T: 2.5 SECONDS

AC404608AB

When the lock signal from the keyless entry transmitter is received into ETACS-ECU, all doors are locked and the horn sounds. If the driver's door cannot be locked even when the keyless entry transmitter is operated, the horn does not sound.

### LIFTGATE UNLOCK FUNCTION

Press the "LIFTGATE" button twice within 5 seconds and the liftgate will be unlocked.

### TIMED LOCKING MECHANISM

After unlocking the doors with the keyless entry transmitter, if no doors are opened, if the ignition key is not inserted or if the locking function is not operated, the ETACS-ECU automatically locks the doors in 30 seconds.

### SUNROOF

#### SUNROOF TIMER FUNCTION

The ETACS-ECU enables opening and closing of the sunroof for 30 seconds after the ignition is switched off.

During this timed operation, if the driver's door or passenger's door is opened, the sunroof timer function is deactivated from that moment.

**WINDSHIELD WIPER AND WASHER**

**INTERMITTENT CONTROL (VEHICLE SPEED-DEPENDENT VARIABLE TYPE)**

ETACS-ECU uses the dial position of the variable intermittent wiper control switch and the vehicle speed signal sent by the combination meter to calculate the interval to be sent to the front-ECU.

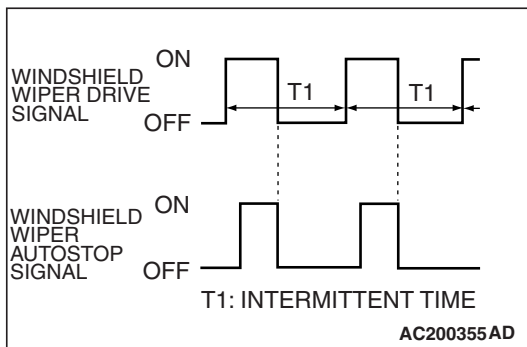
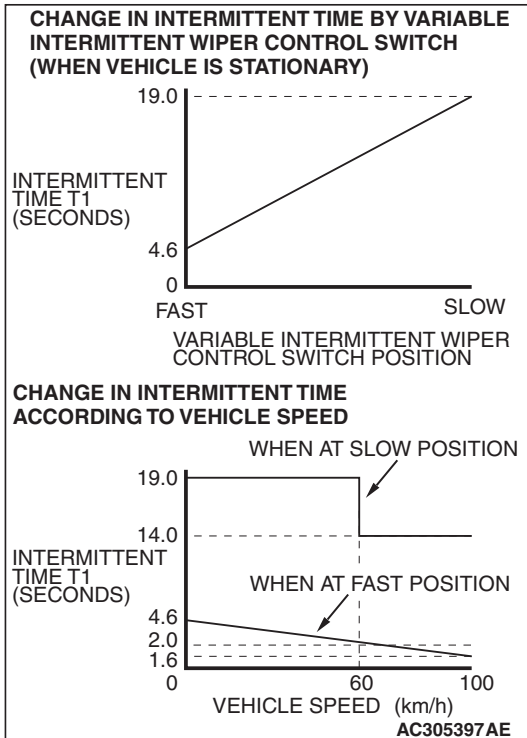

The front-ECU determines the intermittent time T1 from the input SWS data signal, and turns ON the windshield wiper drive signal. When the wiper is at the STOP position, the windshield wiper auto-stop signal goes OFF then turn OFF the windshield wiper drive signal. After the intermittent time T1 seconds from when the windshield wiper drive signal turned ON, the windshield wiper drive signal is turned ON again and the above operation is repeated.

*NOTE: If the intermittent time T1 is within 2 seconds, the wiper is operated consecutively at LOW-speed by the front-ECU.*

**Mist wiper control**

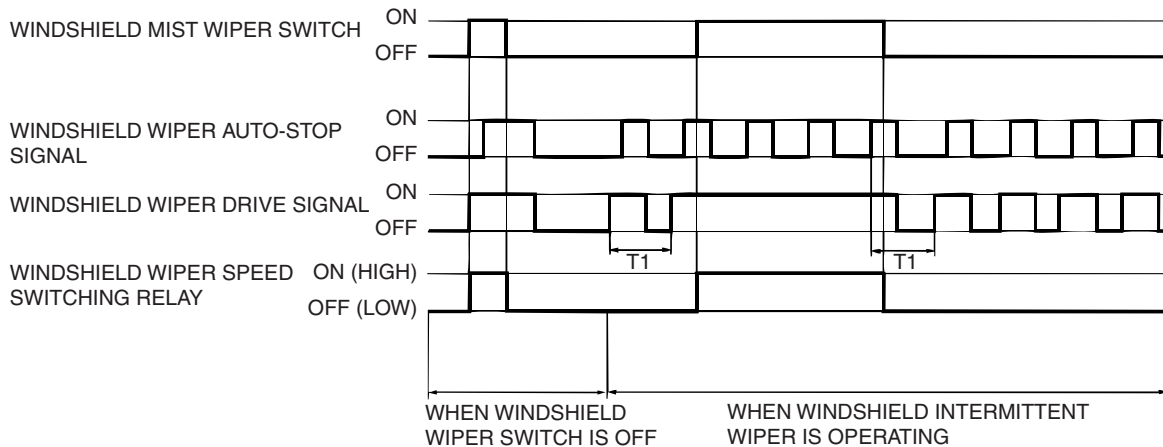

When the ignition switch is in the ACC or ON position, and the windshield mist wiper switch of the column switch is turned ON, the front-ECU turns ON the windshield wiper drive signal. At the same time, the wiper speed switching relay is turned ON (HIGH-SPEED). While the windshield mist wiper switch is ON, the windshield wiper will operate at high speed. Then, if the windshield mist wiper switch is turned off, the wiper operates at low speed until it stops at the predetermined park position.

When the windshield mist switch is turned on briefly, the wiper operates once at low speed. At the point the windshield mist switch is turned ON, if the windshield wiper has been operating intermittently, the same operations as the above will be performed while the windshield mist wiper switch is ON. After the windshield mist wiper switch goes OFF, the intermittent operations will be set again T1 seconds after the last windshield wiper auto-stop signal turning ON.

**Low-speed wiper, high-speed wiper control**

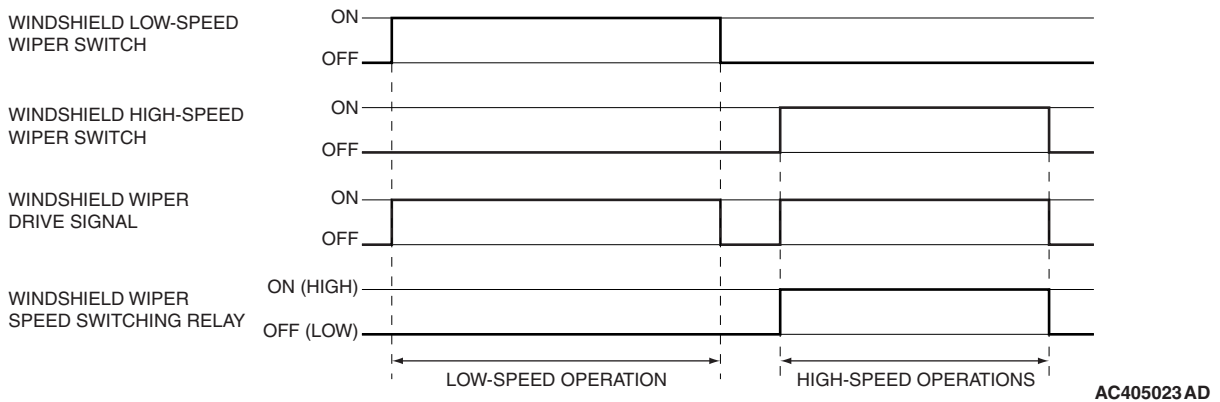

When the ignition switch in at the ACC or ON position, and the windshield low-speed wiper switch of the column switch is turned ON, the front-ECU turns ON the windshield wiper drive signal, turns OFF (LOW) the windshield wiper speed relay, and operates the windshield wiper at low-speed. Next, when

the windshield high speed wiper switch is turned ON, the windshield wiper drive signal is turned ON, the windshield wiper speed switching relay is turned ON (HIGH), and the windshield wiper is operated at high-speed.

**Washer control**

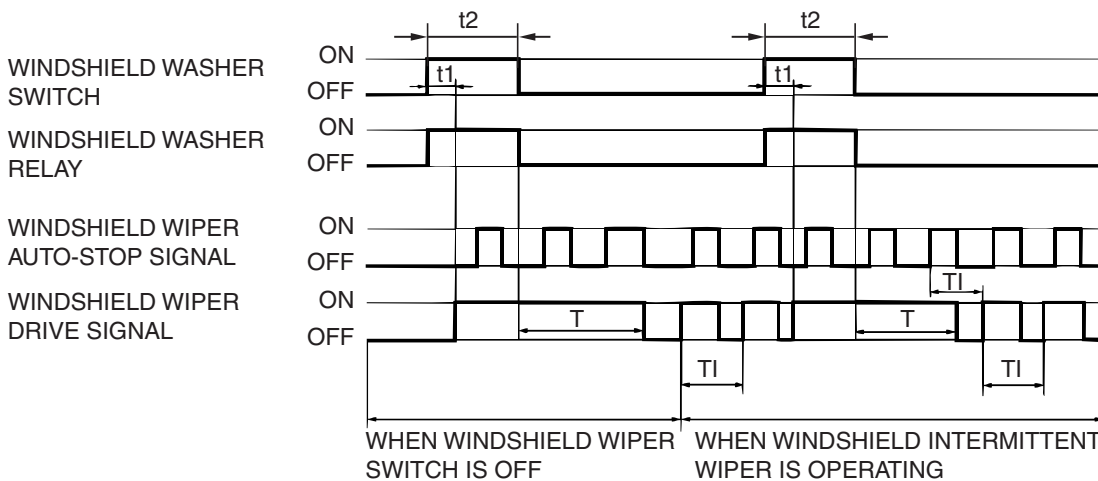

T: WIPER OPERATING TIME AFTER WINDSHIELD WASHER SWITCH IS OFF

T1: INTERMITTENT TIME    t1: 0.15 SECOND    t2: WINDSHIELD WASHER OPERATING TIME

AC306460AC

When the ignition switch is in the ACC or ON position, and the windshield washer switch of the column switch is turned ON, the front-ECU turns ON the windshield washer relay. The windshield wiper drive signal is turned ON after 0.15 second until 2 seconds

after the windshield washer switch goes OFF to operate the windshield wiper continuously. When the windshield washer switch is turned ON, if the windshield wiper is operating intermittently, intermittent operation will resume after two or three wipes.

NOTE: The wiper drive signal output time varies according to the conditions. Refer to the following table for details.

	WHEN WIPER SWITCH IS OFF			WHEN WIPER SWITCH IS SET TO INT			WHEN WIPER SWITCH IS SET TO LO OR HI			
	t2	0.15 second or less	0.15 - 0.8 second	0.8 second or more	0.15 second or less	0.15 - 0.8 second	0.8 second or more	0.15 second or less	0.15 - 0.8 second	0.8 second or more
T	0 second	1.2 seconds	2 seconds	0 second	1.2 seconds	2 seconds	0 second	1.2 seconds	2 seconds	2 seconds

**REAR WIPER AND WASHER**

**Rear wiper control**

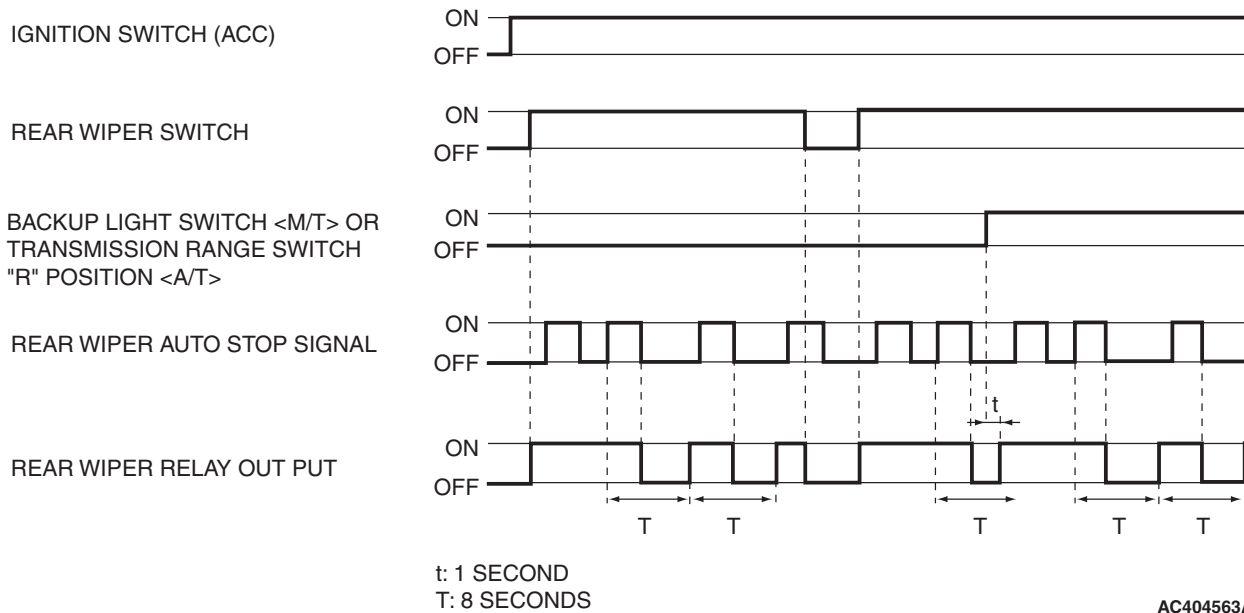

**Intermittent control (basic control)**

When the rear wiper switch on the column switch is turned ON with the ignition switch ACC or ON, ETACS-ECU turns ON the rear wiper relay and operates the rear wiper twice consecutively. After that, operation continues at 8-second intervals.

**"R" position-linked control**

When the shift lever <M/T> or the selector lever <A/T> is moved to R (reverse) position during the rear wiper operation, the backup light switch <M/T> or the transmission range switch R (reverse) <A/T> turns ON. One second after that, the ETACS-ECU turns the rear wiper relay ON, and operates the rear wiper twice consecutively.

NOTE: If the rear wiper switch is turned OFF or the backup light switch <M/T> or the transmission range switch R (reverse) <A/T> is turned OFF while the rear wiper is operating twice consecutively, the rear wiper relay will be turned OFF and the rear wiper will be stopped.

**Rear washer control**

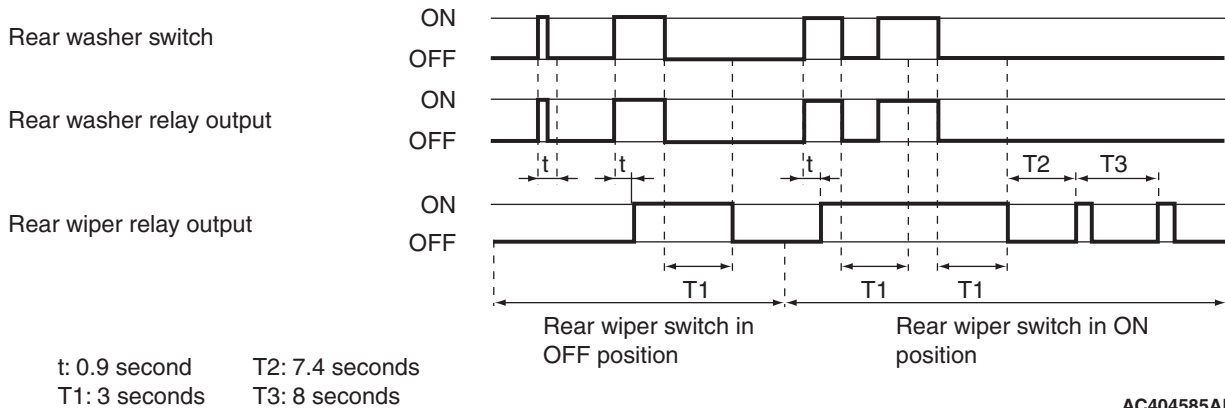

When the rear washer switch on the column switch is turned ON with the ignition switch ACC or ON, the ETACS-ECU turns ON the rear washer relay. If the rear washer switch remains ON for 0.9 second or more, the rear wiper operates. 3 seconds after the rear washer switch is turned OFF, the rear wiper is stopped.

If the rear washer switch is turned ON during the intermittent operation of the rear wiper, the rear wiper operates along with the rear washer consecutively. 7.4 seconds after the rear wiper stops consecutive operation, it returns to the intermittent operation.

**HEADLIGHTS AND TAILLIGHTS**

**TAILLIGHTS**

If the column switch sends a taillight switch "ON" signal to the front-ECU, the front-ECU turns on its taillight relay, causing the taillights to illuminate.

*NOTE: This description covers the taillights only. In actual driving, the taillights may be turned off due to the headlight automatic shut-off function. For details on the headlight automatic shut-off function, refer to P.54B-22.*

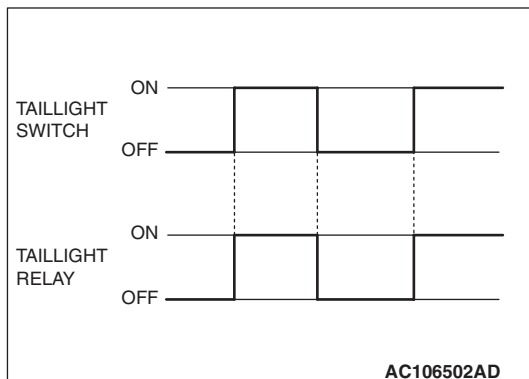

Headlights

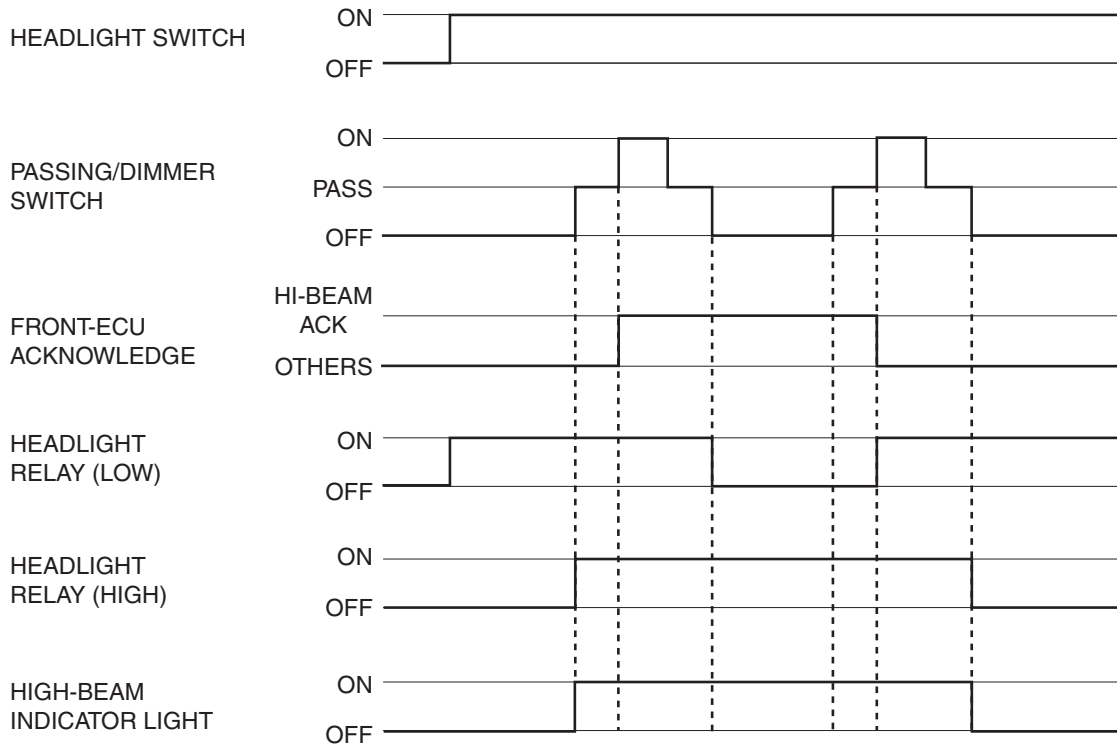

AC306461AC

If the column switch sends a headlight switch "ON" signal to the front-ECU, the front-ECU turns on its headlight relay (LOW), causing the low-beam headlights to illuminate. If the dimmer switch is turned on while the headlight relay (LOW) is on, the front-ECU turns on the headlight relay (HIGH), causing the high-beam headlights to illuminate.

*NOTE: This description covers the headlights only. In actual driving, the headlights may be turned off due to the headlight automatic shut-off function. For details on the headlight automatic shut-off function, refer to P.54B-22.*

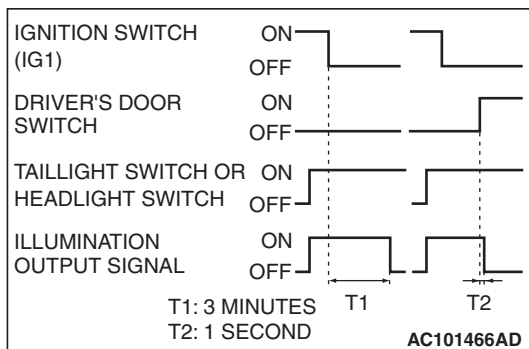

**HEADLIGHT AUTOMATIC-SHUTOFF FUNCTION**

Even if the lighting switch (taillights switch or headlight switch) is ON, the headlight (including the taillights) will automatically go off in the following conditions to prevent the battery from discharging as a result of forgetting to turn off lights.

When the ignition key is turned from "ON" to "LOCK" (OFF) or "ACC" position with the lighting switch turned ON, and this state continues for three minutes, the light will automatically be turned off. If the driver's door is opened during these three minutes, the light will go off one second later.

**HIGH-BEAM INDICATOR**

At the same time that the high-beams are illuminated, the ETACS-ECU sends a signal to illuminate the high-beam indicator via the CAN bus line. The combination meter receives the transmitted signal and turns the high-beam indicator on and off.

**Daytime running light function**

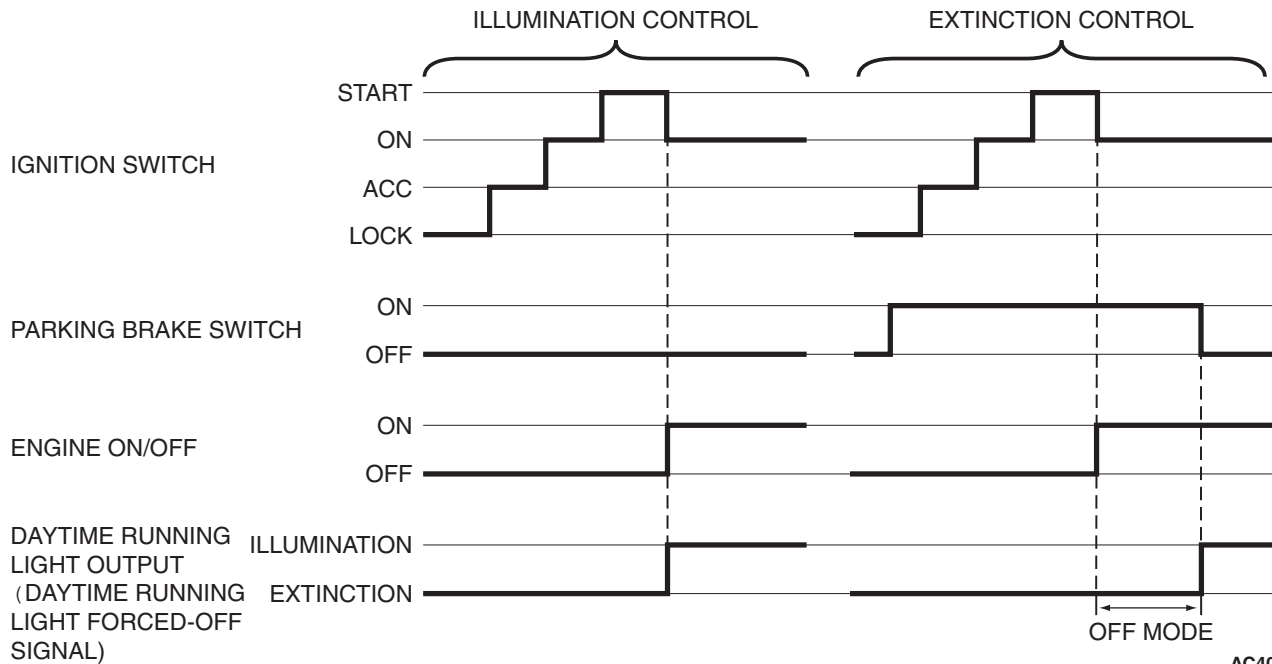

AC404726AB

The ETACS-ECU outputs the daytime running light forced-OFF signal to the front-ECU based on the input signal sent via CAN communication. The front-ECU controls illumination and extinction of the daytime running light according to the daytime running light forced-OFF signal.

**Illumination control of daytime running lights**

- If the engine is started when the parking brake is not pulled, the headlights illuminate with the brightness reduced.
- If the engine is started while the parking brake is pulled, the daytime running light function OFF mode is entered and the headlights do not illuminate. If the parking brake is released, the OFF mode is cancelled and the headlights illuminate.

**FLASHER TIMER**

**TURN-SIGNAL LIGHT**

The turn-signal light output (flashing signal) is turned ON when the ignition switch is ON and the turn-signal light switch is ON (LH or RH). If the front or rear turn-signal light bulb has burned out, the flashing speed increases to indicate that the bulb has burned out.

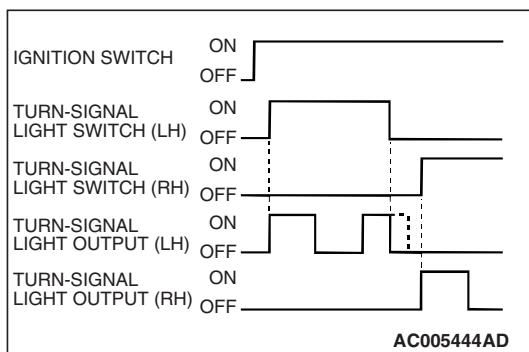

AC005444AD

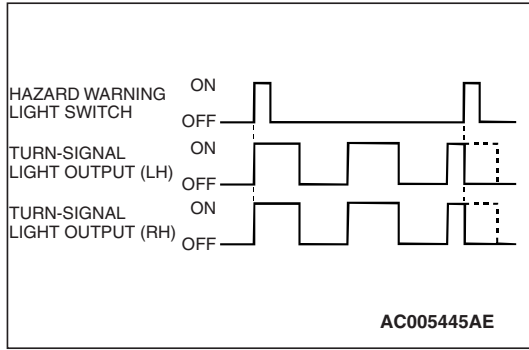

**HAZARD WARNING LIGHT**

Detects the signal where the hazard warning light switch input changes from OFF to ON, and reverses the flashing state according to this signal. The hazard warning lights toggle on and off whenever the hazard warning light switch is operated.

*NOTE: The hazard warning light switch is a push-return type toggle switch.*

**TURN-SIGNAL INDICATORS**

At the same time that the turn-signal lights are illuminated, the ETACS-ECU sends a signal to illuminate the turn-signal light indicator via the CAN bus line. The combination meter receives the transmitted signal and turns the turn-signal light indicator on and off.

**FRONT FOG LIGHT**

**Front fog light**

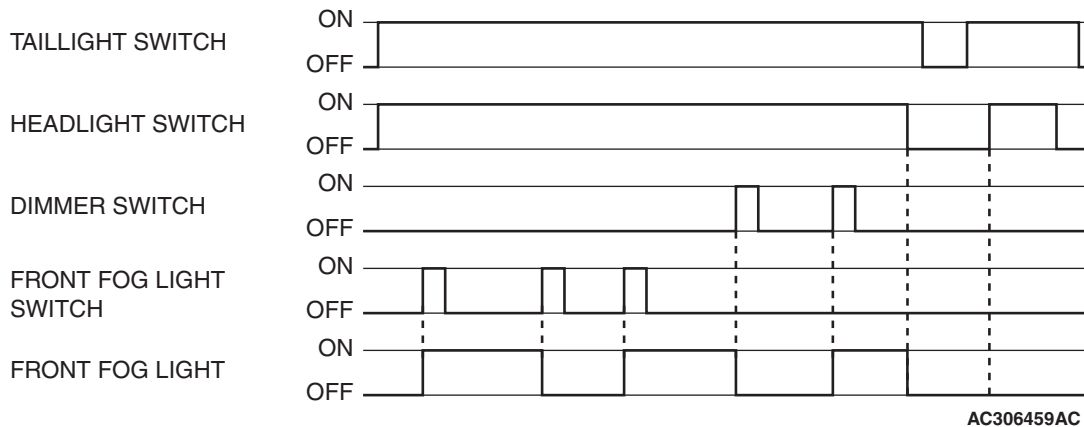

The front fog lights will illuminate only when the front fog light switch is operated while the low-beam headlights are on.

The front fog lights will be switched off when any of the following conditions are met. The front fog lights will also be switched off automatically by headlight automatic shutoff function.

- When the high-beam headlights are switched on, the front fog lights will be switched off. If the low-beam headlights are switched on again, the front fog lights will illuminate again.
- When the headlight switch is turned off or the taillights and headlights are off, the front fog lights will be switched off. If the low-beam headlights are switched on again, the front fog lights will not illuminate again.

**FRONT FOG LIGHT INDICATOR**

At the same time that the front fog lights are illuminated, the ETACS-ECU sends a signal to illuminate the front fog light indicator via the CAN bus line. The combination meter receives the transmitted signal and turns the front fog light indicator on and off.

## INTERIOR LIGHT

### INTERIOR LIGHT CONTROL

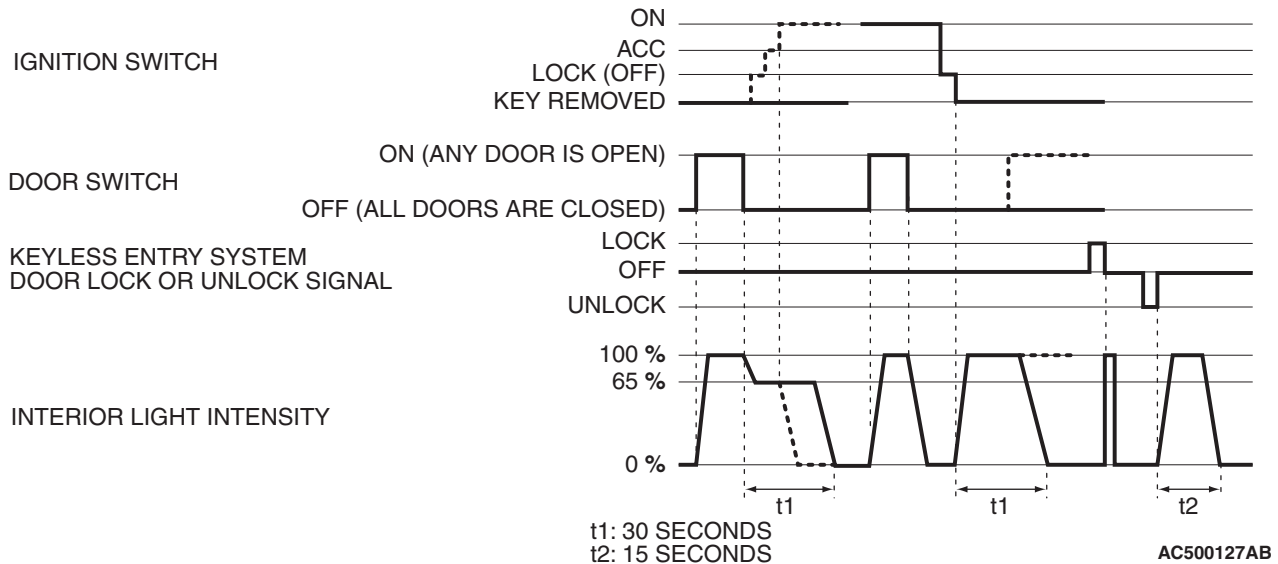

The ETACS-ECU controls the interior lights by turning them on and off in the following way:

- When a door is opened with the ignition switch off, the interior lights up to a luminance of 100 percent. When a door is closed, the interior lights dim to a luminance of 65 percent, and go off 30 seconds later. However if the ignition switch is turned ON or if a door is locked while the interior lights are dimming, the dome light will go off at that point.
- When a door is opened with the ignition switch ON, the interior lights up at a luminance of 100 percent. When a door is closed, the interior lights go off.

- When the ignition key is removed with all doors closed, the interior lights up at a luminance of 100 percent, and goes off 30 seconds later. However if the ignition key is inserted again or if a door is locked while the interior lights is lighting, the interior lights will go off at that point.
- To check keyless entry operations more easily, the interior lights flash once when the doors are locked. When the doors are unlocked, the interior lights at a luminance of 100 percent, and go off 15 seconds later.

*NOTE: The dotted lines indicate that lighting mode when the ignition switch is turned ON, door is locked, or any door is opened during the timer illumination time.*

### Interior light automatic-shutoff function

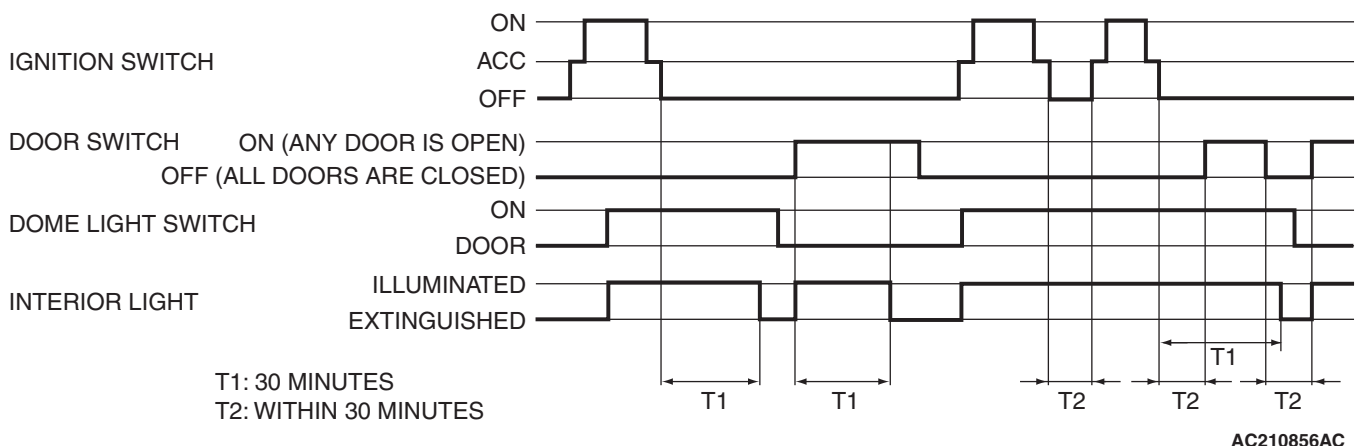

Illuminated interior lights such as the front dome light, etc. (all lights using the dome light fuse as the power supply) will automatically go off in the following conditions to prevent the battery from discharging as a result of forgetting to turn off the lights or incomplete closing of the door.

- When the ignition switch is turned off and more than 30 minutes pass with the interior light illuminated, the interior lights will go off automatically.
- When the ignition switch is turned off and one of the door switches remains open for 30 minutes continuously, the interior lights will go off automatically.

**Seat belt indicator**

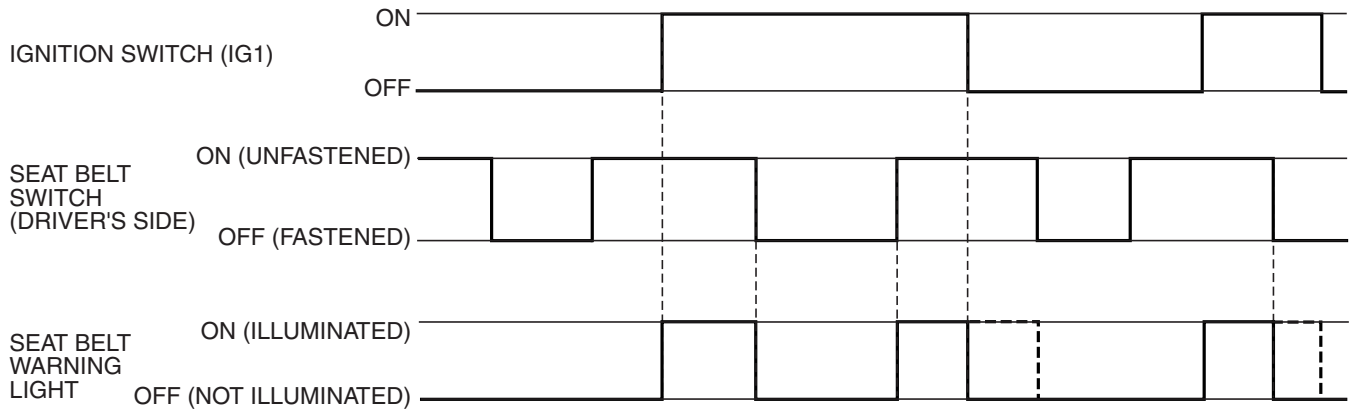

AC305420 AC

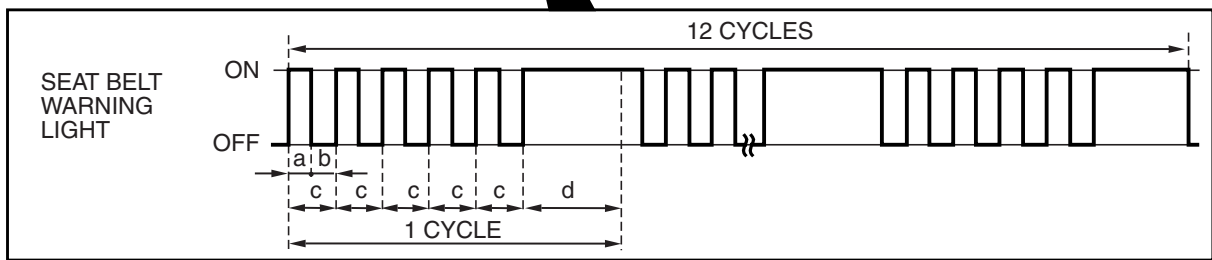
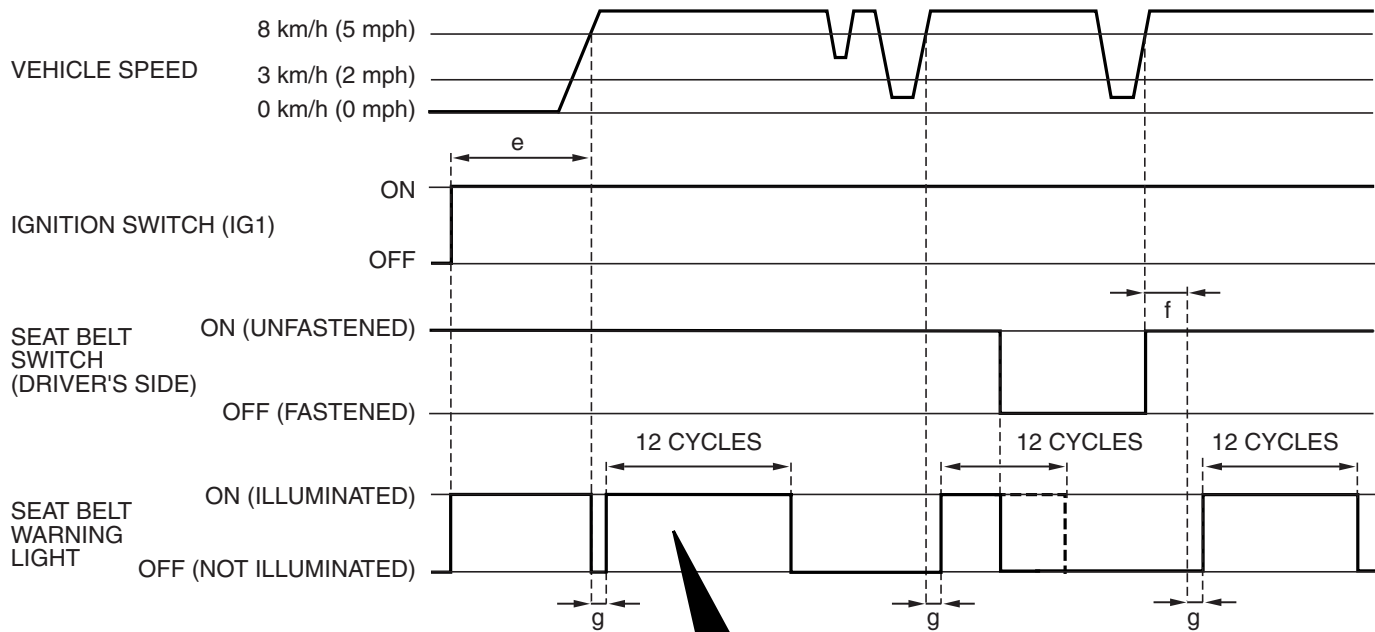

a: 0.48 SECOND  
b: 0.52 SECOND

c: 1 SECOND  
d: 3 SECONDS

e: 60 SECONDS OR MORE  
f: 10 SECONDS

g: 0.5 SECOND

AC305443AB

If any of the following conditions are met with the ignition switch at "ON" or "ST", the ETACS-ECU illuminates or extinguishes the seat belt indicator by using the driver's seat belt switch signal and the vehicle speed signal from the combination meter.

- The seat belt indicator illuminates when the seat belt switch is turned on (driver's seat belt is not fastened) with the ignition switch "ON".
- Flashes and illuminates the indicator 12 cycles (after 0.5 second) if any of the following conditions are met when 60 seconds or more have elapsed since the ignition switch is turned "ON". One cycle consists of five-second "flash" and then three-second "illuminate".

- The vehicle speed has reached 8 km/h (5 mph) while the seat belt switch is turned on (driver's seat belt is not fastened) with the ignition switch "ON".
- The seat belt switch has been turned on (driver's seat belt has not been fastened) for at least 10 seconds while the ignition switch has been turned "ON" and the vehicle speed has been 8 km/h (5 mph) or more.

*NOTE: Once this timer operation has been activated, it will not be activated again until the vehicle speed reduces to 3 km/h (2 mph) or less even if any of the following conditions are met.*

- The indicator turns off if the ignition switch or the seat belt switch is turned off (the driver's seat belt is fastened) while the timer operation is active.

**DOOR AJAR INDICATOR**

The combination meter receives the signal sent from the ETACS-ECU about whether each door is open or closed and turns the door ajar indicator on and off. While the door ajar indicator is illuminated, the door ajar tone alarm function is activated and the door ajar indicator flashes 4 times. If the door remains open even after the 4 warning flashes, the door ajar indicator will be illuminated again. And when the interior light automatic-shutoff function is activated, the door ajar indicator is extinguished.

**IGNITION KEY CYLINDER ILLUMINATION FUNCTION**

The ignition key cylinder illumination light illuminates when the driver's door is opened with the ignition switch off, and for 30 seconds after the driver's door is closed. It also illuminates for 30 seconds after the ignition key is pulled out. In any case, it goes out when the ignition switch is turned on.

*NOTE: When the ignition key cylinder illumination is extinguished by the interior light automatic-shutoff function, it does not illuminate.*